

EE 435

Lecture 16

Compensation of Feedback Amplifiers

How does the Gain of the Two-Stage Miller-Compensated Op Amp Compare with Internal Compensated Op Amp?

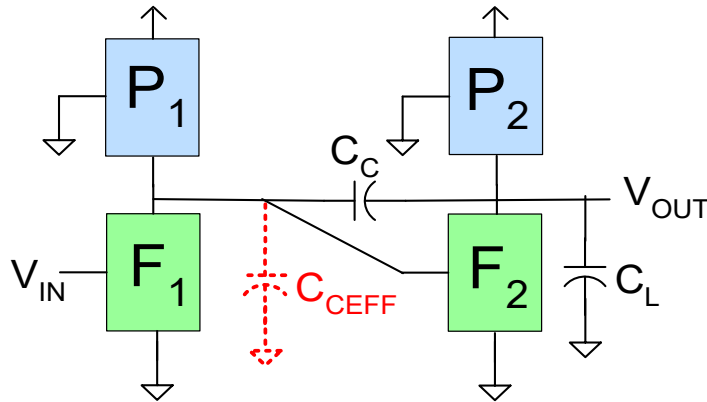

$$A(s) = \frac{g_{md}(g_{m0} - sC_C)}{s^2 C_C C_L + s g_{m0} C_C + g_{oo} g_{od}}$$

$$A(s) = A_0 \frac{\frac{s}{\tilde{z}_1} + 1}{\left(\frac{s}{\tilde{p}_1} + 1\right)\left(\frac{s}{\tilde{p}_2} + 1\right)}$$

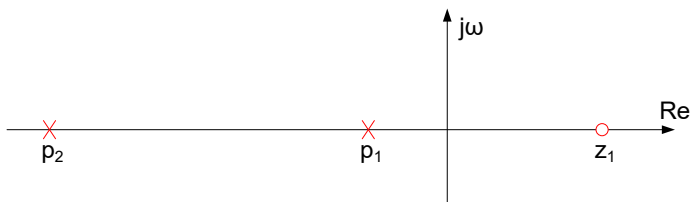

must be developed

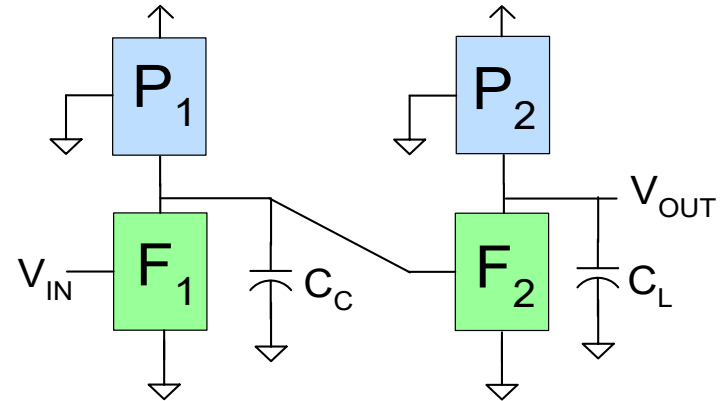

$$A(s) \cong \frac{g_{md} g_{m0}}{s^2 C_C C_L + s C_C g_{oo} + g_{oo} g_{od}}$$

$$A(s) = A_0 \frac{1}{\left(\frac{s}{\tilde{p}_1} + 1\right)\left(\frac{s}{\tilde{p}_2} + 1\right)}$$

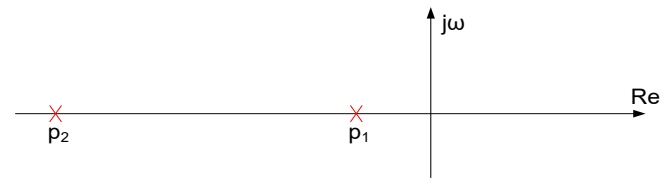

Compensation criteria:

$$4\beta A_0 > \frac{p_2}{p_1} > 2\beta A_0$$

Feedback applications of the two-stage Op Amp

Open-loop Gain

$$A(s) = \frac{N(s)}{D(s)}$$

Standard Feedback Gain

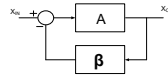

$$A_{FB}(s) = \frac{A(s)}{1 + A(s)\beta(s)} = \frac{N(s)}{D(s) + N(s)\beta(s)} \stackrel{\text{def n}}{=} \frac{N_{FB}(s)}{D_{FB}(s)}$$

$$N_{FB}(s) = N(s)$$

$$D_{FB}(s) = D(s) + \beta(s)N(s)$$

- Open-loop and closed-loop zeros identical
- Closed-loop poles different than open-loop poles
- Often $\beta(s)$ is not dependent upon frequency

What closed-loop pole Q is typically required when compensating an op amp?

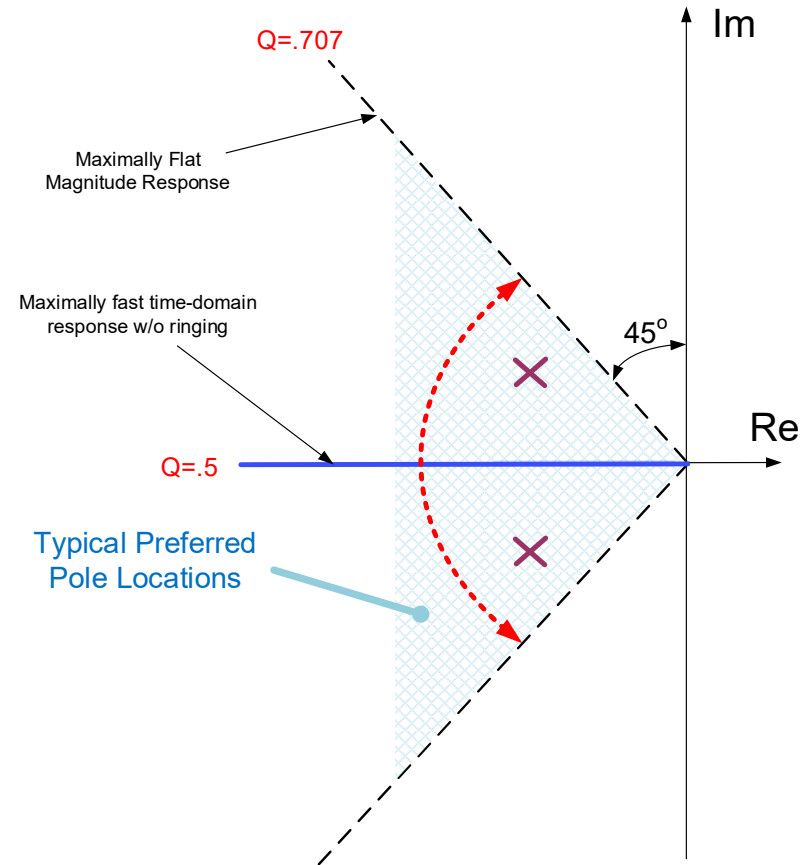
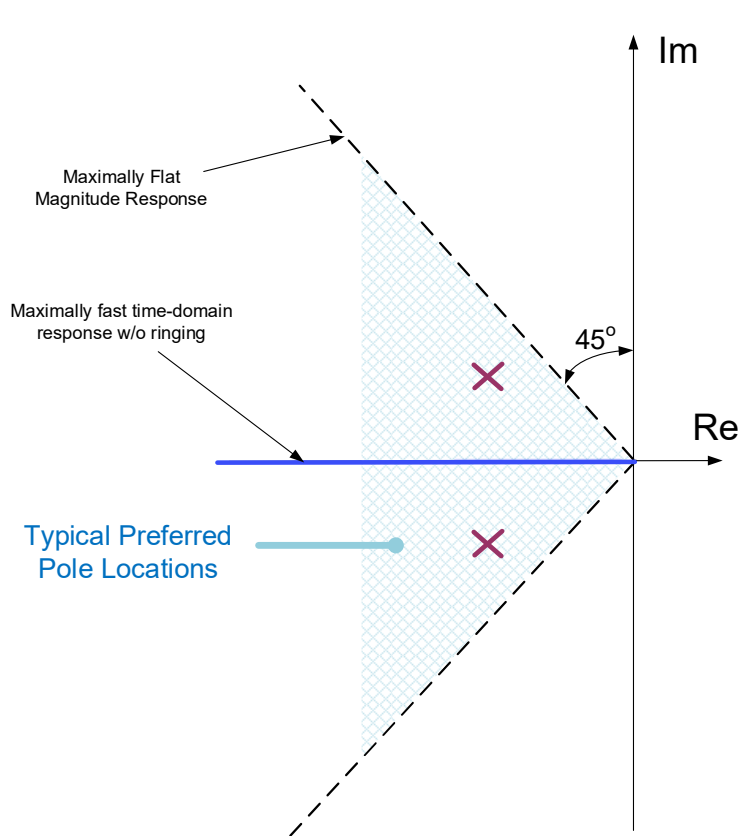

Recall:

Typically compensate so closed-loop poles make angle between 45° and 90° from imaginary axis

Equivalently:

$$0.5 < Q < .707$$

Basic Two-Stage Op Amp

(with Miller compensation)

Standard Feedback Gain

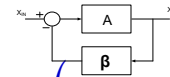

$$A_{FB}(s) \cong \frac{g_{md}(g_{mo} - sC_c)}{s^2 C_c C_L + s C_c (g_{mo} - \beta g_{md}) + \beta g_{md} g_{mo}}$$

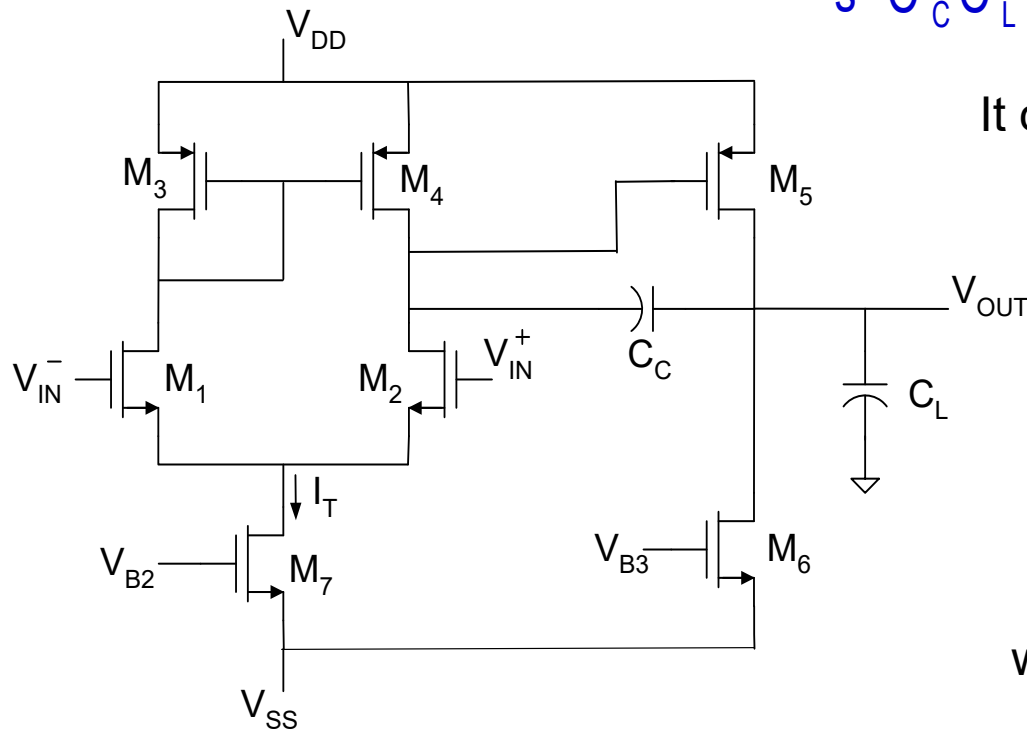

It can be shown that

$$Q = \sqrt{\frac{C_L}{C_c}} \sqrt{\beta} \frac{\sqrt{g_{mo} g_{md}}}{g_{mo} - \beta g_{md}}$$

$$C_c = \frac{C_L \beta}{Q^2} \frac{g_{mo} g_{md}}{(g_{mo} - \beta g_{md})^2}$$

where $g_{md} = g_{m1}$ $g_{mo} = g_{m5}$

$g_{oo} = g_{o5} + g_{o6}$ and $g_{od} = g_{o2} + g_{o4}$

But what pole Q is desired? $.707 < Q < 0.5$

Right Half-Plane Zero in OL Gain (from Miller Compensation) Limits Performance

(because it increases the pole Q and thus requires a larger C_c !)

Closed-form expression for C_c !

Basic Two-Stage Op Amp with Feedback

(with Internal Node compensation)

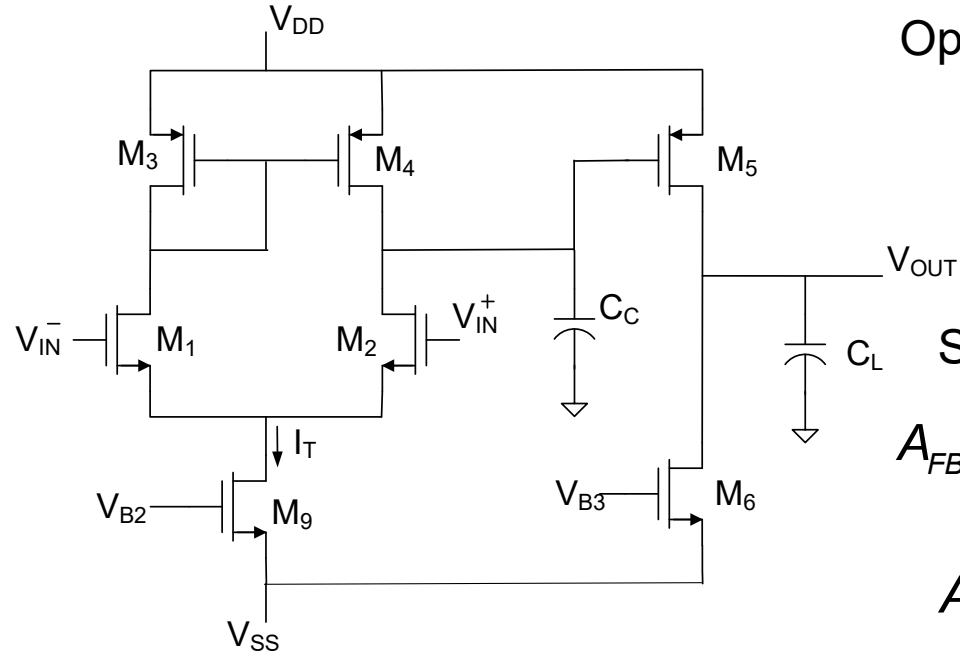

Open-loop gain

$$A(s) = \frac{g_{m0}g_{md}}{s^2C_C C_L + sC_C g_{o0} + g_{o0}g_{od}}$$

$$A_{FB} = \frac{A}{1 + A\beta}$$

Standard feedback gain with constant β

$$A_{FB}(s) = \frac{g_{m0}g_{md}}{s^2C_C C_L + sC_C g_{o0} + g_{o0}g_{od} + \beta g_{m0}g_{md}}$$

$$A_{FB}(s) \cong \frac{g_{m0}g_{md}}{s^2C_C C_L + sC_C g_{o0} + \beta g_{m0}g_{md}}$$

where

$$g_{o0} = g_{o5} + g_{o6}$$

$$g_{m0} = g_{m5}$$

$$g_{od} = g_{o2} + g_{o4}$$

$$g_{md} = g_{m1}$$

$$4\beta A_0 > \frac{p_2}{p_1} > 2\beta A_0$$

$$p_2 = \frac{g_{o0}}{C_L} \quad p_1 = \frac{g_{od}}{C_C} \quad A_0 = \frac{g_{m0}g_{md}}{g_{o0}g_{od}}$$

$$C_L 4\beta \frac{g_{m0}g_{md}}{g_{o0}^2} > C_C > C_L 2\beta \frac{g_{m0}g_{md}}{g_{o0}^2}$$

OR

$$C_C = C_L \beta \frac{g_{m0}g_{md}}{Q^2 g_{o0}^2} = C_L \beta \frac{g_{m5}g_{m1}}{Q^2 (g_{o5} + g_{o6})^2}$$

Status on Compensation

Generally not needed for single-stage op amps

Analytical expressions were developed with $A_{FB} = \frac{A}{1+A\beta}$ for

Two-stage with internal node compensation (no OL zeros)

Two-stage with load compensation (no OL zeros)

Two-stage with basic Miller compensation (OL zero, single series comp cap)

Will now develop a more general compensation strategy

Compensation

What is “compensation” or “frequency compensation”?

From Wikipedia: In [electrical engineering](#), **frequency compensation** is a technique used in [amplifiers](#), and especially in amplifiers employing negative feedback. It usually has two primary goals: To avoid the unintentional creation of [positive feedback](#), which will cause the amplifier to [oscillate](#), and to control [overshoot](#) and [ringing](#) in the amplifier's [step response](#).

From Martin and Johns – no specific definition but makes comparisons with “optimal compensation” which also is not defined

From Allen and Holberg (p 243) The goal of compensation is to maintain stability when negative feedback is applied around the op amp.

Compensation

From Gray and Meyer (p634) Thus if this amplifier is to be used in a feedback loop with loop gain larger than $a_0 f_1$, efforts must be made to increase the phase margin. This process is known as compensation.

From Sedra and Smith (p 90) This process of modifying the open-loop gain is termed frequency compensation, and its purpose is to ensure that op-amp circuits will be stable (as opposed to oscillatory).

From Razavi (p355) Typical op amp circuit contain many poles. In a folded-cascode topology, for example, both the folding node and the output node contribute poles. For this reason, op amps must usually be “compensated”, that is, their open-loop transfer function must be modified such that the closed-loop circuit is stable and the time response is well-behaved.

Compensation

What is “compensation” or “frequency compensation” and what is the goal of compensation?

Nobody defines it or defines it correctly but everybody tries to do it !

Compensation

Compensation (alt Frequency Compensation) is the manipulation of the poles and/or zeros of the open-loop amplifier so that when feedback is applied, the closed-loop amplifier will perform acceptably

Note this definition does not mention stability, positive feedback, negative feedback, phase margin, or oscillation.

Note that acceptable performance is strictly determined by the user in the context of the specific application

Compensation (better definition)

Compensation (alt Frequency Compensation) is the manipulation of the poles and/or zeros of the open-loop amplifier so that when feedback is applied, the closed-loop ~~amplifier~~ will perform acceptably.
circuit

Note this definition does not mention stability, positive feedback, negative feedback, phase margin, or oscillation.

Note that acceptable performance is strictly determined by the user in the context of the specific application

Note this covers linear applications of op amps beyond just finite-gain amplifiers

Approach to Studying Compensation

Will attempt to develop a correct understanding of the concept of compensation rather than plunge into a procedure for “doing compensation”

Compensation requires the use of some classical mathematical concepts

Compensation

Compensation is the manipulation of the poles and/or zeros of the open-loop amplifier so that when feedback is applied, the closed-loop circuit will perform acceptably

Acceptable performance is often application dependent and somewhat interpretation dependent

Acceptable performance should include effects of process and temperature variations

Although some think of compensation as a method of maintaining stability with feedback, acceptable performance generally dictates much more stringent performance than simply stability

Compensation criteria are often an indirect indicator of some type of desired (but unstated) performance

Varying approaches and criteria are used for compensation often resulting in similar but not identical performance

Over compensation often comes at a considerable expense (increased power, decreased frequency response, increased area, ...)

Compensation

Compensation requirements usually determined by closed-loop pole locations:

$$A_{OL}(s) = \frac{N(s)}{D(s)} \quad A_{CL}(s) = \frac{N_{FB}(s)}{D_{FB}(s)} \quad \Rightarrow \quad D_{FB}(s) = D(s) + \beta(s)N(s)$$

- Often Phase Margin or Gain Margin criteria are used instead of pole Q criteria when compensating amplifiers
(for historical reasons but must still be conversant with this approach)
- Nyquist plots are an alternative concept that can be used for compensating amplifiers
- Phase Margin and Gain Margin criteria are directly related to the Nyquist Plots
- Compensation requirements are strongly β dependent

Characteristic Polynomial obtained from denominator term of basic feedback equation

$$D_{FB}(s) = 1 + A(s)\beta(s)$$

$$A(s)\beta(s)$$

defined to be the “loop gain” of a feedback amplifier

Review of Basic Concepts

Pole Locations and Stability

$$D_{\text{FB}}(s) = 1 + A(s)\beta(s)$$

Theorem: A system is stable iff all closed-loop poles lie in the open left half-plane.

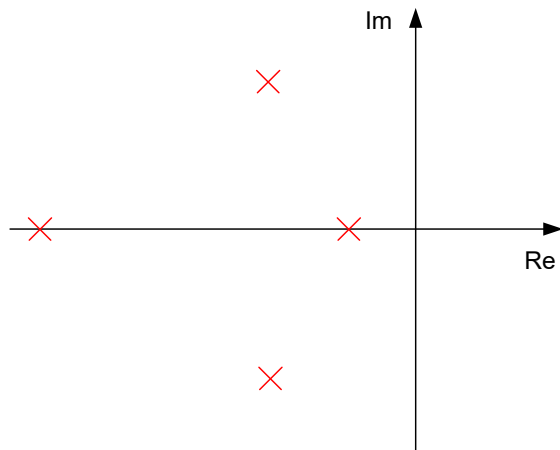

Stable

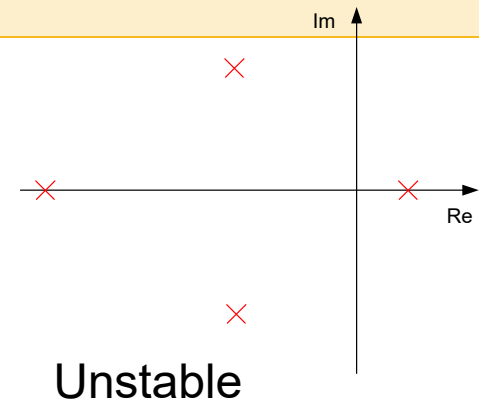

Unstable

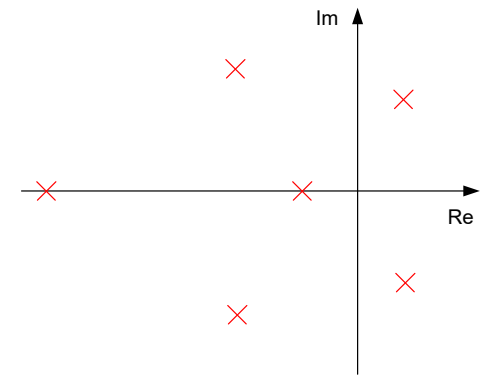

Unstable

Review of Basic Concepts (from last lecture)

Consider a second-order factor of a denominator polynomial, $P(s)$, expressed in integer-monic form

$$P(s) = s^2 + a_1s + a_0$$

Then $P(s)$ can be expressed in several alternative but equivalent ways

$$(s - p_1)(s - p_2)$$

if complex conjugate poles or real axis poles of same sign

$$s^2 + s \frac{\omega_0}{Q} + \omega_0^2$$

$$s^2 + s2\zeta\omega_0 + \omega_0^2$$

if real – axis poles

$$(s - p_1)(s - kp_1)$$

and if complex conjugate poles,

$$(s + \alpha + j\beta)(s + \alpha - j\beta)$$

$$(s + re^{j\theta})(s + re^{-j\theta})$$

Widely used alternate parameter sets:

$$\{ (a_1, a_2) (\omega_0, Q) (\omega_0, \zeta) (p_1, p_2) (p_1, k) (\alpha, \beta) (r, \theta) \}$$

These are all 2-parameter characterizations of the second-order factor and it is easy to map from any one characterization to any other

Review of Basic Concepts (from last lecture)

$$s^2 + s \frac{\omega_0}{Q} + \omega_0^2$$

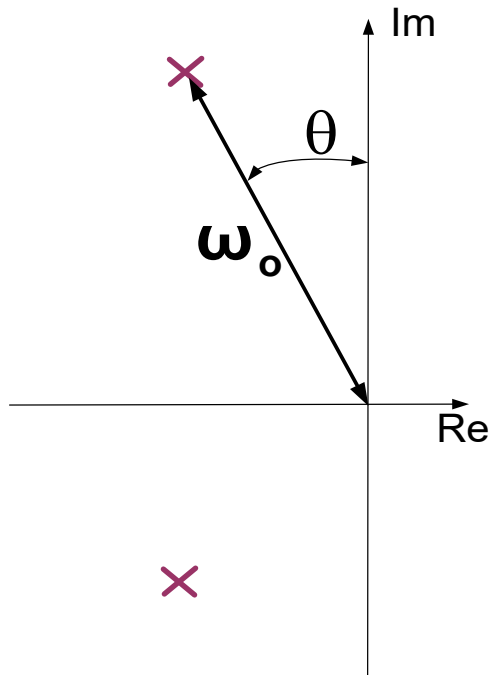

$$\sin\theta = \frac{1}{2Q}$$

ω_0 = magnitude of pole
Q determines the angle of the pole

Observe: $Q=0.5$ corresponds to two identical real-axis poles
 $Q=.707$ corresponds to poles making 45° angle with Im axis

What closed-loop pole Q is typically required when compensating an op amp?

Review of Basic Concepts (from last lecture)

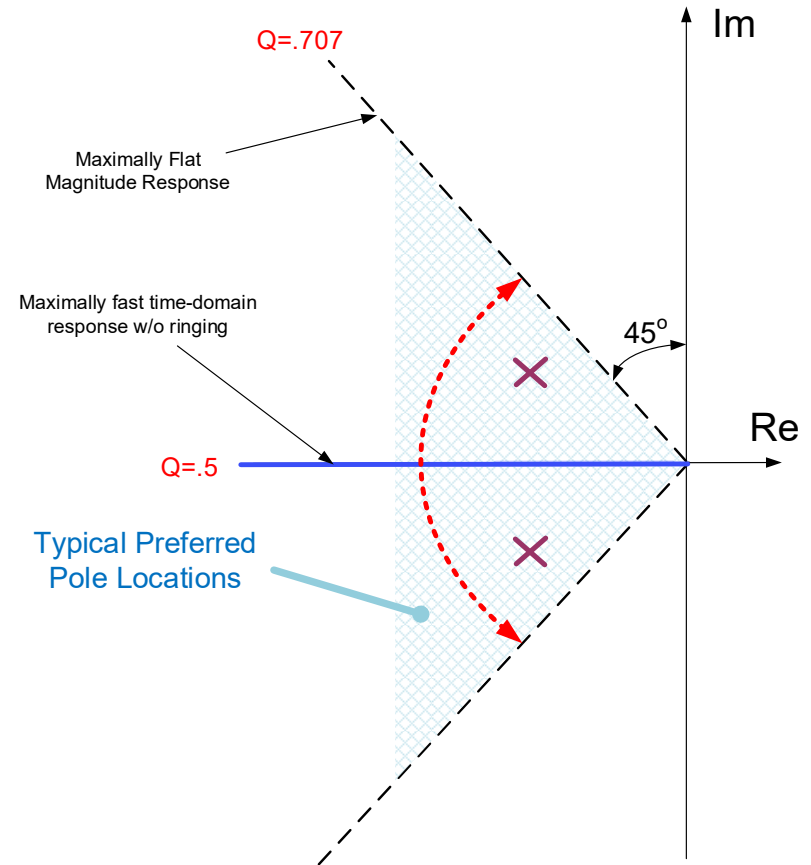
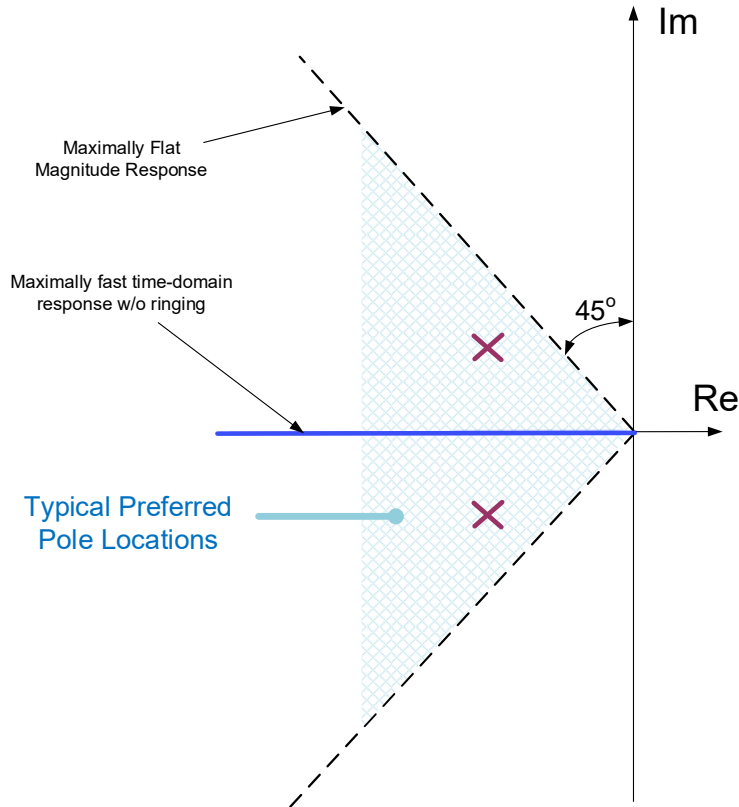

Recall:

Typically compensate so closed-loop poles make angle between 45° and 90° from imaginary axis

Equivalently:

$$0.5 < Q < .707$$

Pole Locations and Stability

Theorem: A system is stable iff all closed-loop poles lie in the open left half-plane.

Note: When designing finite-gain amplifiers with feedback, want to avoid having closed-loop amplifier poles close to the imaginary axis to minimize ringing in the time-domain and/or to minimize peaking in the frequency domain

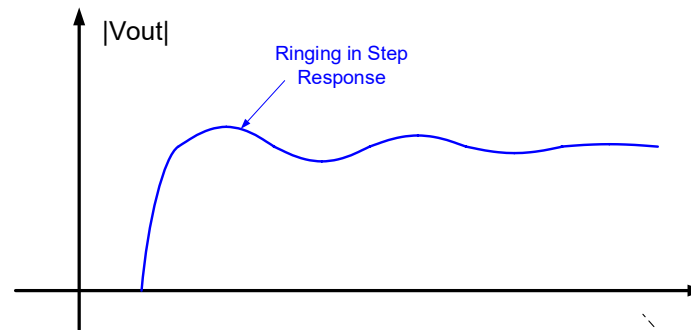
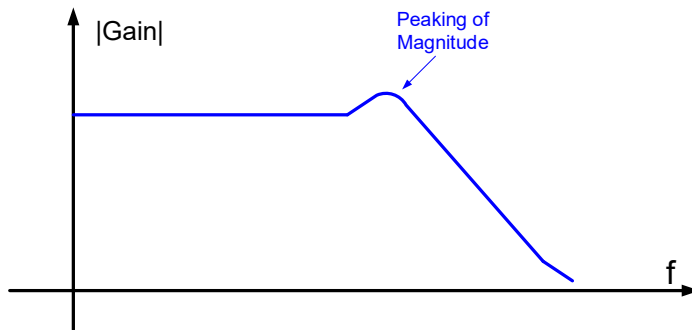

45° pole-pair angle corresponds to $Q = \frac{1}{\sqrt{2}}$
90° pole angle (on pole pair) corresponds to $Q = \frac{1}{2}$

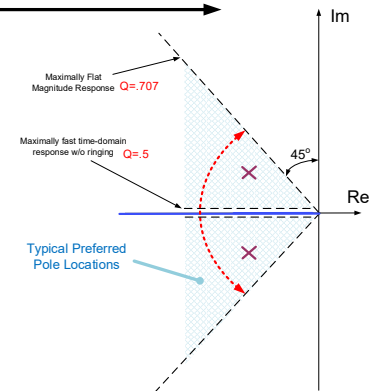

Review of Basic Concepts

Nyquist Plots

$$D_{\text{FB}}(s) = 1 + A(s)\beta(s)$$

The Nyquist Plot is a plot of the Loop Gain ($A\beta$) versus $j\omega$ in the complex plane for $-\infty < \omega < \infty$

Theorem: A system is stable iff the Nyquist Plot does not encircle the point $-1+j0$.

Note: If there are multiple crossings of the real axis by the Nyquist Plot, the term encirclement requires a formal definition that will not be presented here

Note: Multiple crossings issues are often of concern in higher-order control systems but seldom of concern in the compensation of operational amplifiers

Nyquist Plots

$$D_{\text{FB}}(s) = 1 + A(s)\beta(s)$$

Example

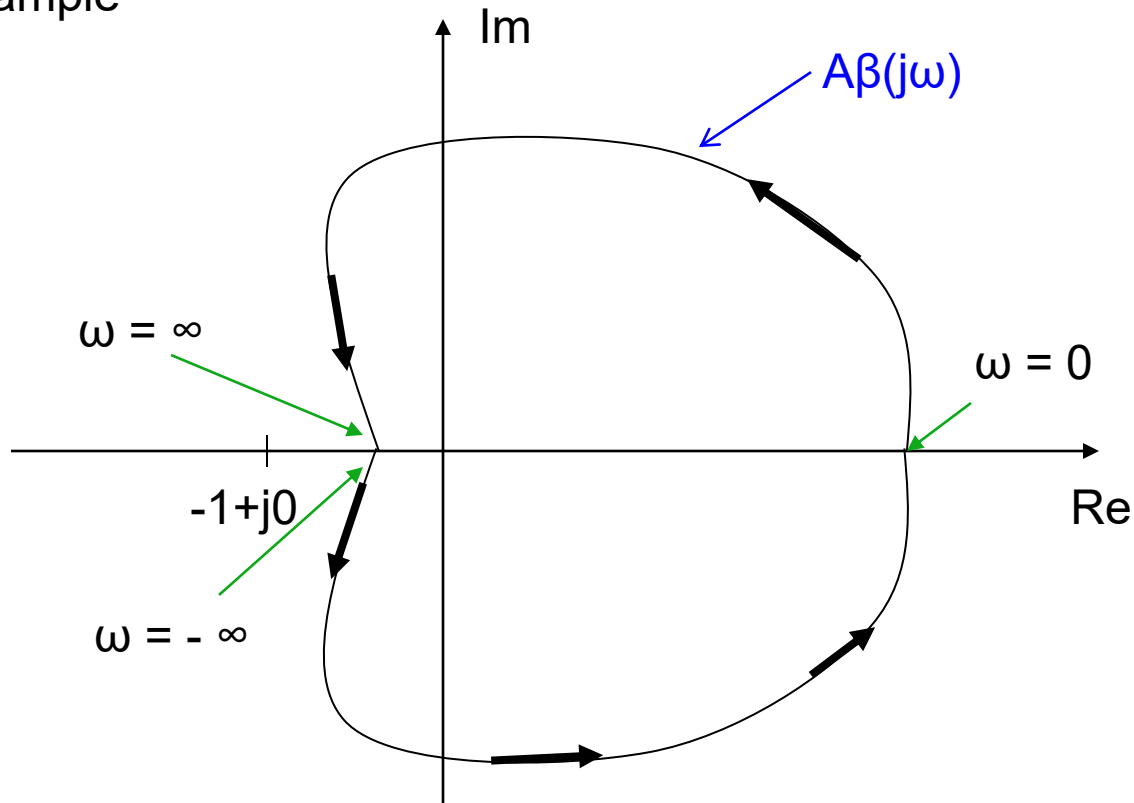

- Stable since $-1+j0$ is not encircled
- Useful for determining stability when few computational tools are available
- Legacy of engineers and mathematicians of pre-computer era

Review of Basic Concepts

Nyquist Plots

$$D_{\text{FB}}(s) = 1 + A(s)\beta(s)$$

Example

$$A(s) = \frac{100}{s+1}$$

$$\beta = 1/2$$

$$A\beta(j\omega) = \frac{50}{j\omega+1}$$

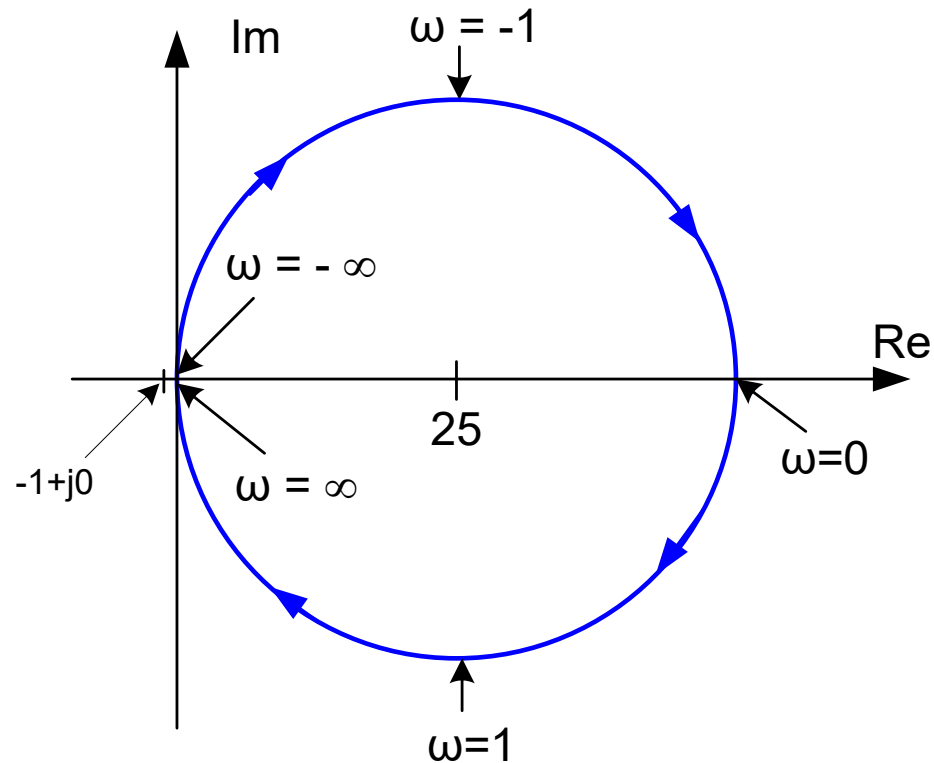

In this example, Nyquist plot is circle of radius 25

Nyquist Plots

$$D_{FB}(s) = 1 + A(s)\beta(s)$$

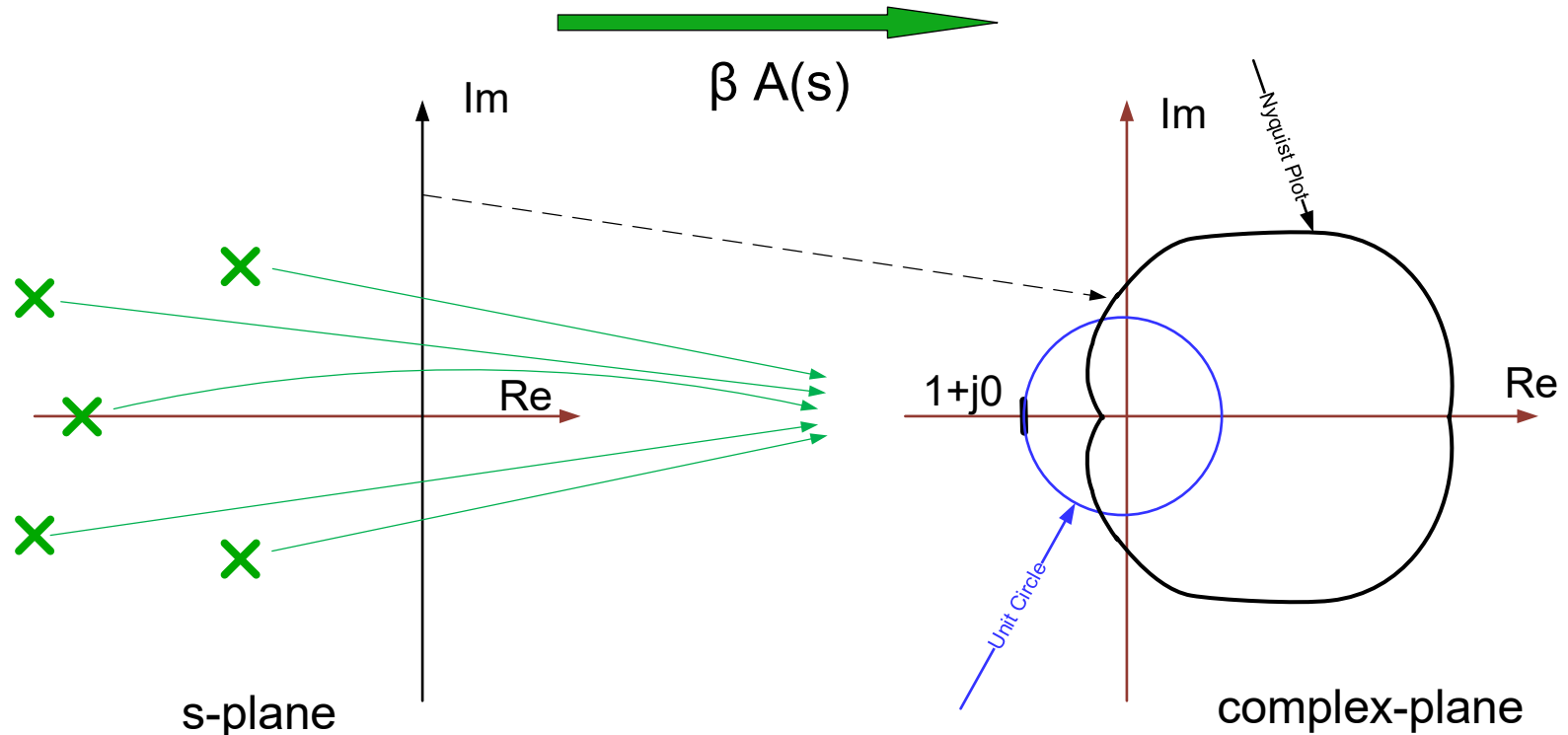

$-1+j0$ is the image of ALL poles

The Nyquist Plot is the image of the entire imaginary axis and separates the image complex plane into two parts

Everything outside of the Nyquist Plot is the image of the LHP

Nyquist plot can be generated with pencil and paper



Important in the '30s - '60's

Review of Basic Concepts

Nyquist Plots

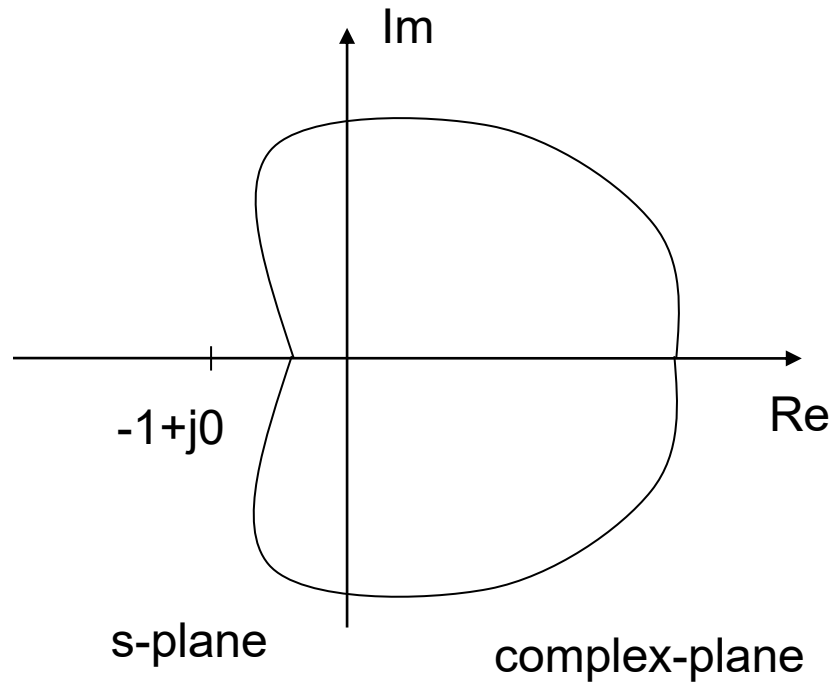

Nyquist plot can be generated with pencil and paper 

Important in the '30s - '60's

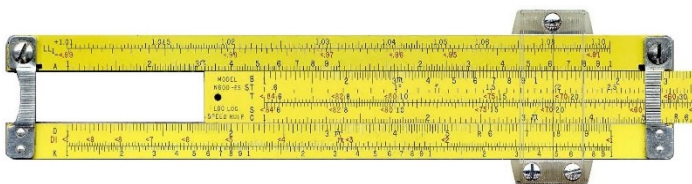

Remember – not even a handheld calculator was available !

Who Invented the Handheld Calculator?

↳ **Jack St. Clair Kilby** (November 8, 1923 – June 20, 2005) was an American electrical engineer who took part (along with [Robert Noyce](#) of [Fairchild](#)) in the realization of the first integrated circuit while working at [Texas Instruments](#) (TI) in 1958. He was awarded the [Nobel Prize in Physics](#) on December 10, 2000.^[1] Kilby was also the co-inventor of the [handheld calculator](#) and the [thermal printer](#), for which he had the patents. He also had patents for seven other inventions.^[2]

Review of Basic Concepts

Nyquist Plots

$$D_{FB}(s) = 1 + A(s)\beta(s)$$

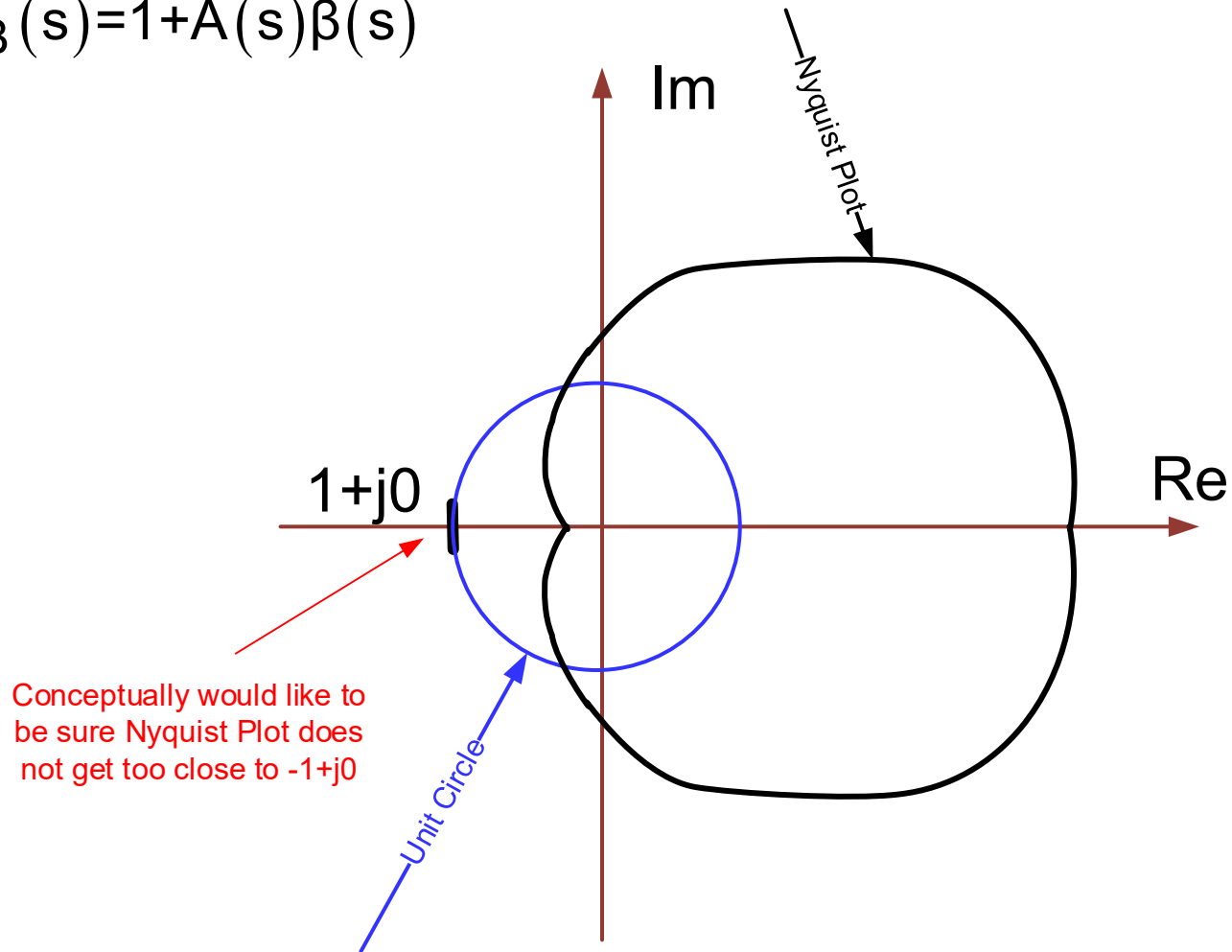

Review of Basic Concepts

Nyquist Plots

$$D_{FB}(s) = 1 + A(s)\beta(s)$$

But identification of a suitable neighborhood is not natural

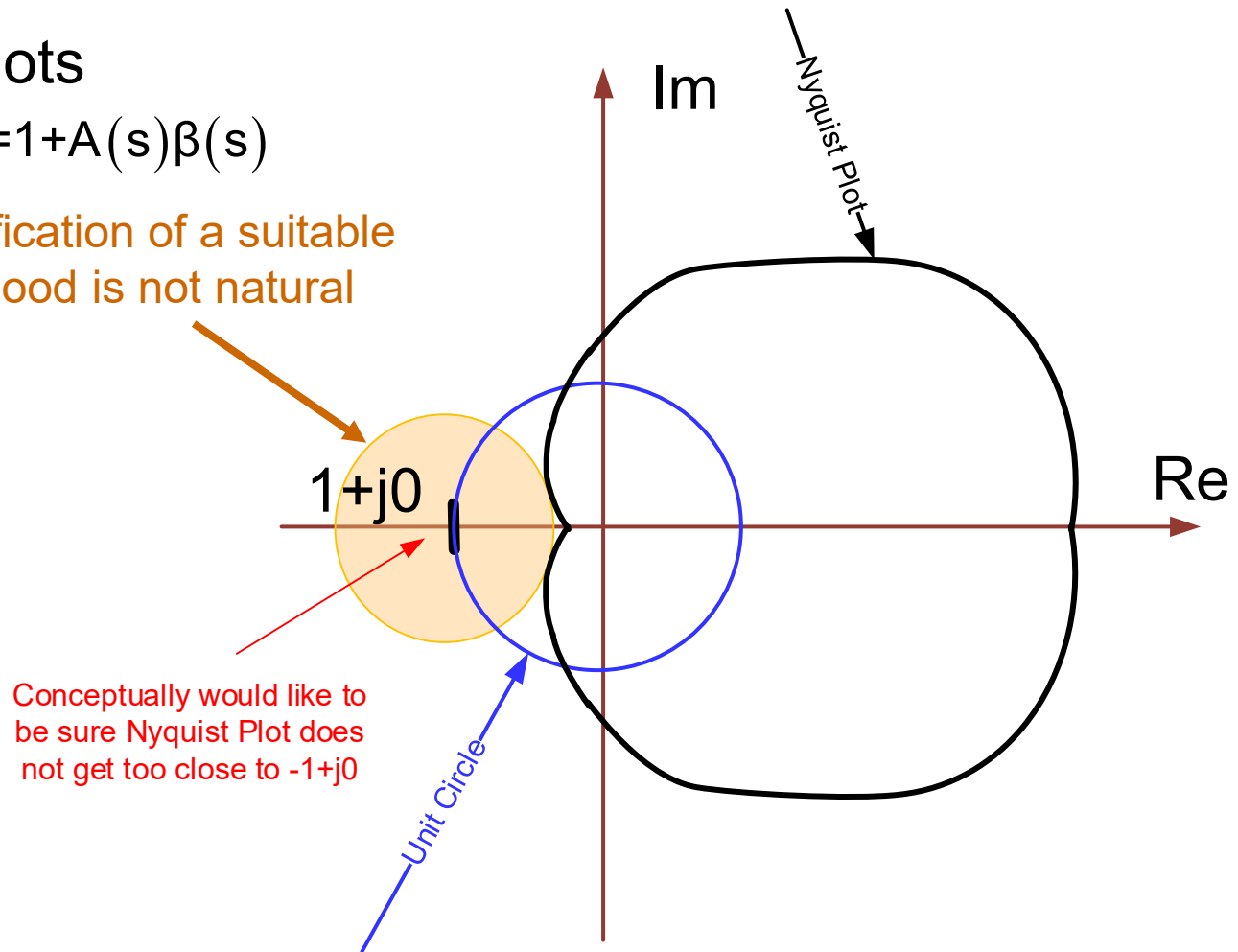

Review of Basic Concepts

Nyquist Plots

Might be useful to be sure image of 45° lines do not encircle $-1+j0$

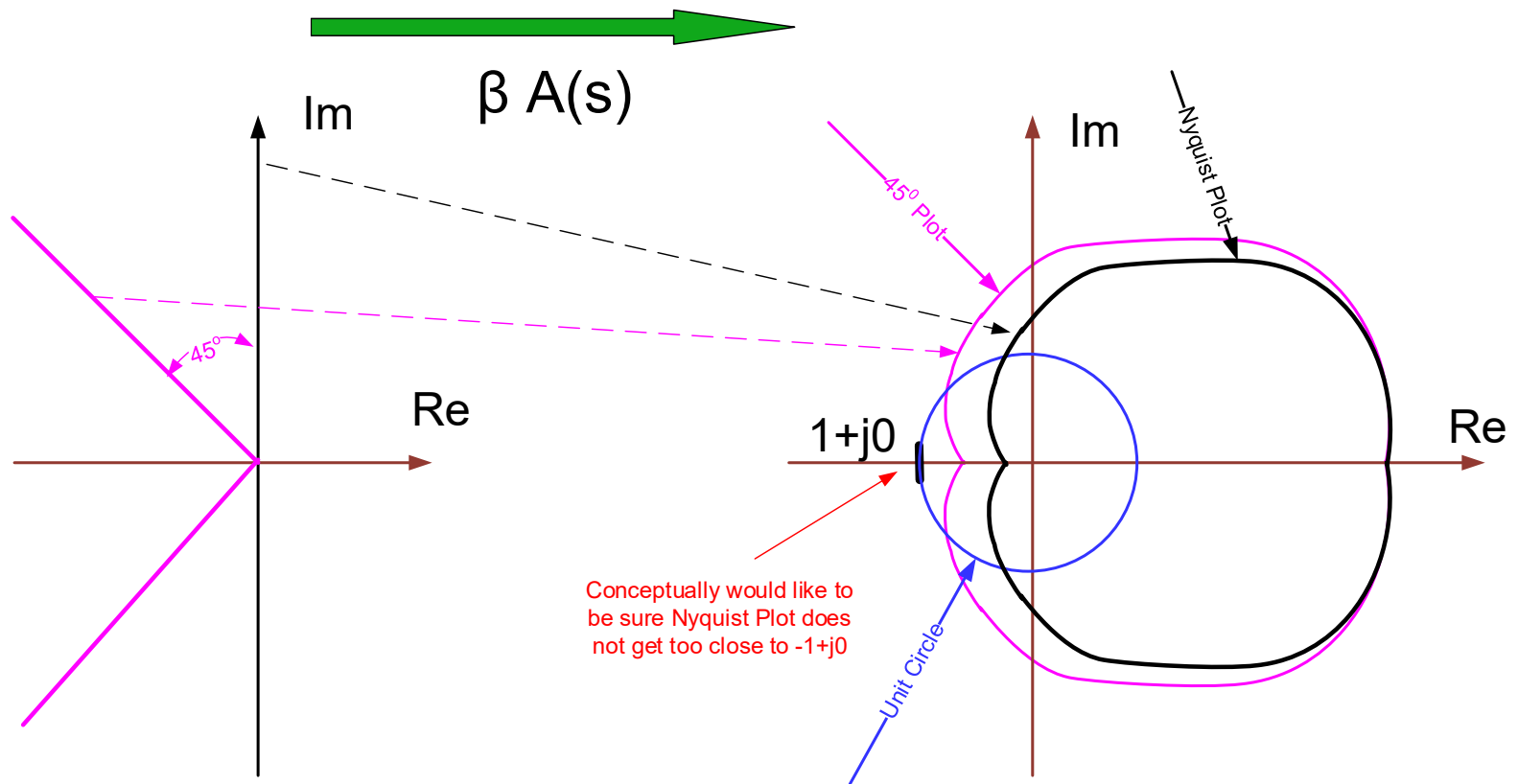

Review of Basic Concepts

Nyquist Plots

What if this happened ?

At least one pole would make an angle of less than 45° wrt Im axis

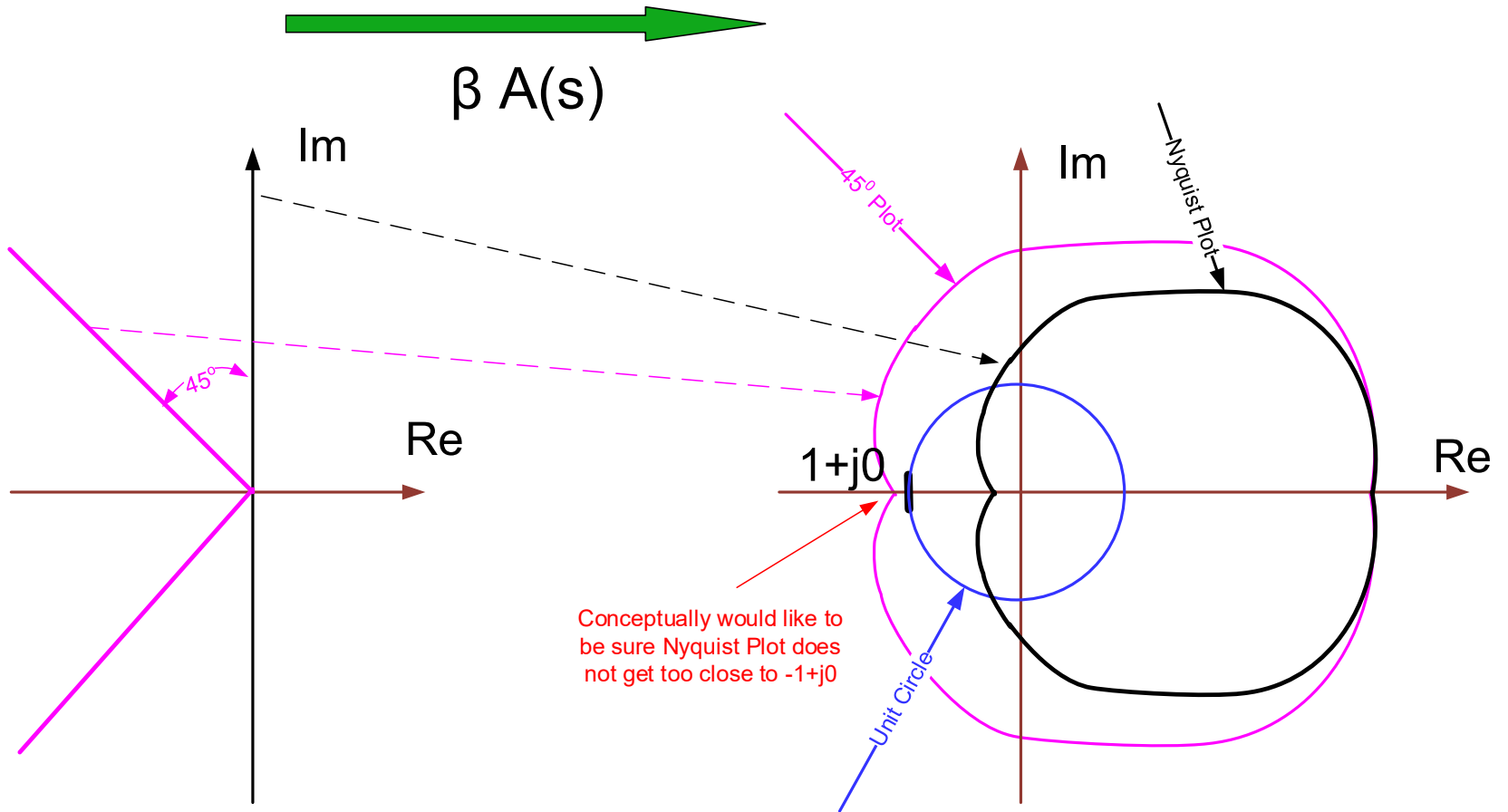

Review of Basic Concepts

Nyquist Plots

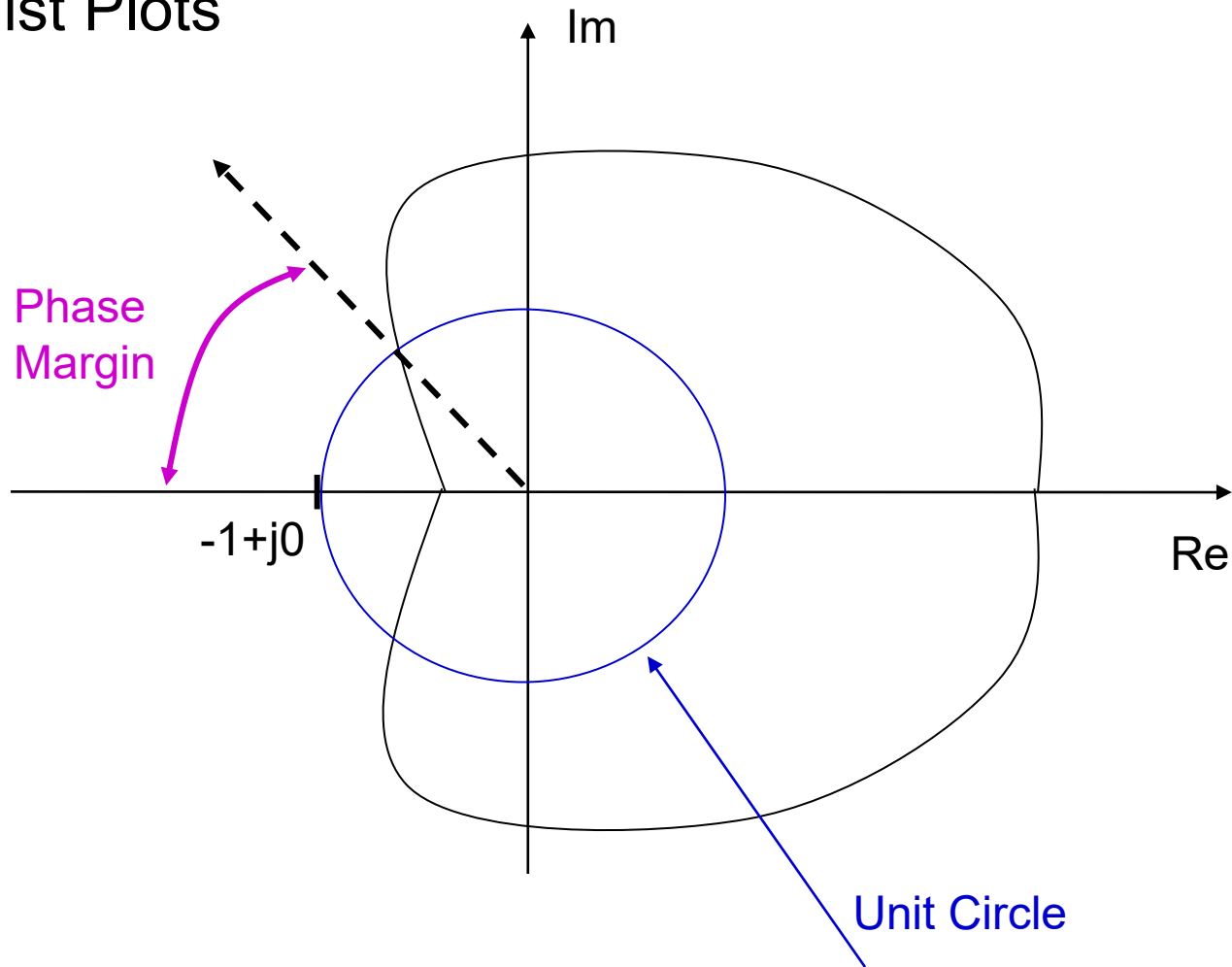

Phase margin is $180^\circ - \text{angle of } A\beta \text{ when the magnitude of } A\beta = 1$

Review of Basic Concepts

Nyquist Plots

$$D_{FB}(s) = 1 + A(s)\beta(s)$$

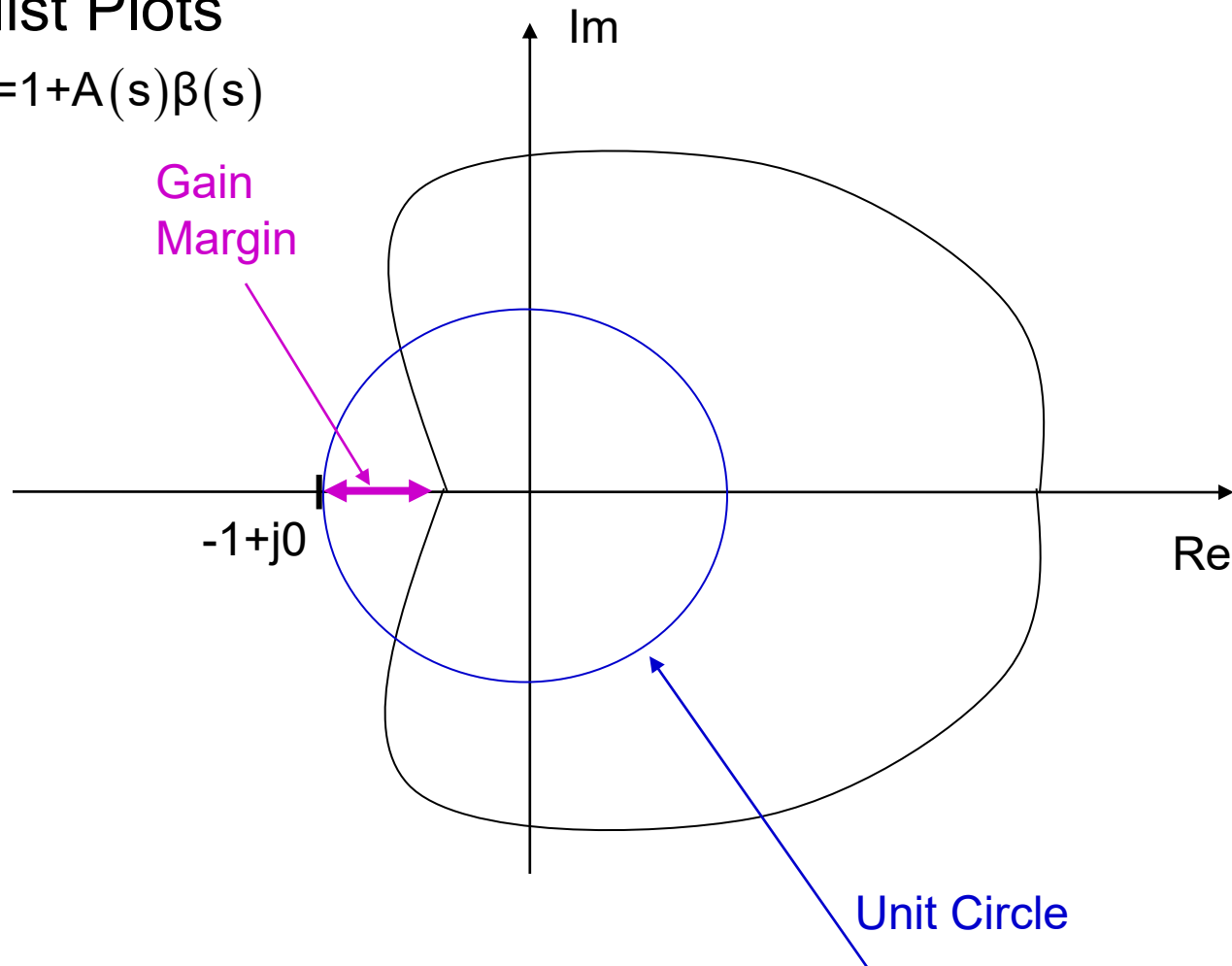

Gain margin is $1 - \text{magnitude of } A\beta$ when the angle of $A\beta = 180^\circ$

Nyquist and Gain-Phase Plots

Nyquist and Gain-Phase Plots convey identical information but gain-phase plots often easier to work with

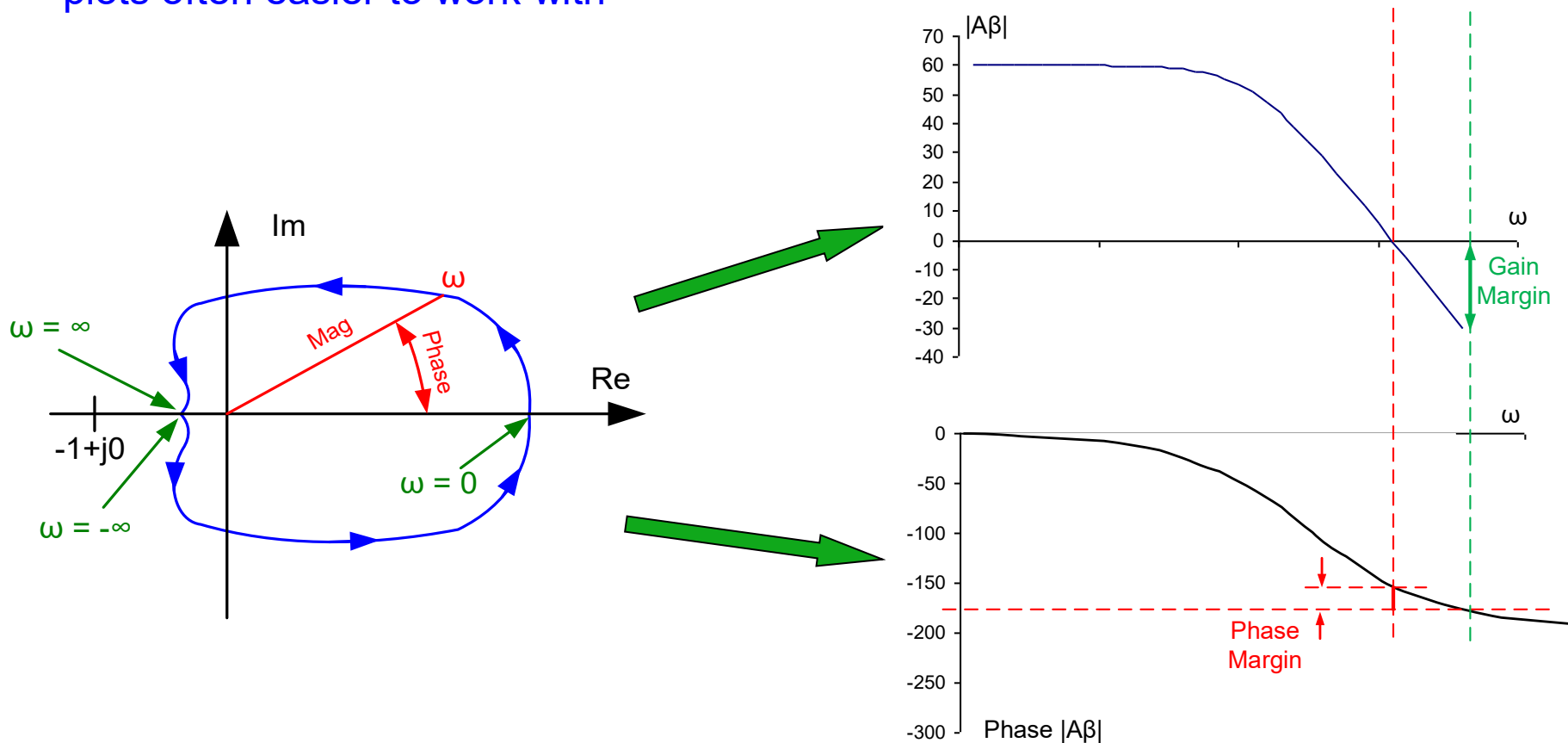

Note: The two plots do not correspond to the same system in this slide

Nyquist and Gain-Phase Plots

Nyquist and Gain-Phase Plots convey identical information but gain-phase plots often easier to work with

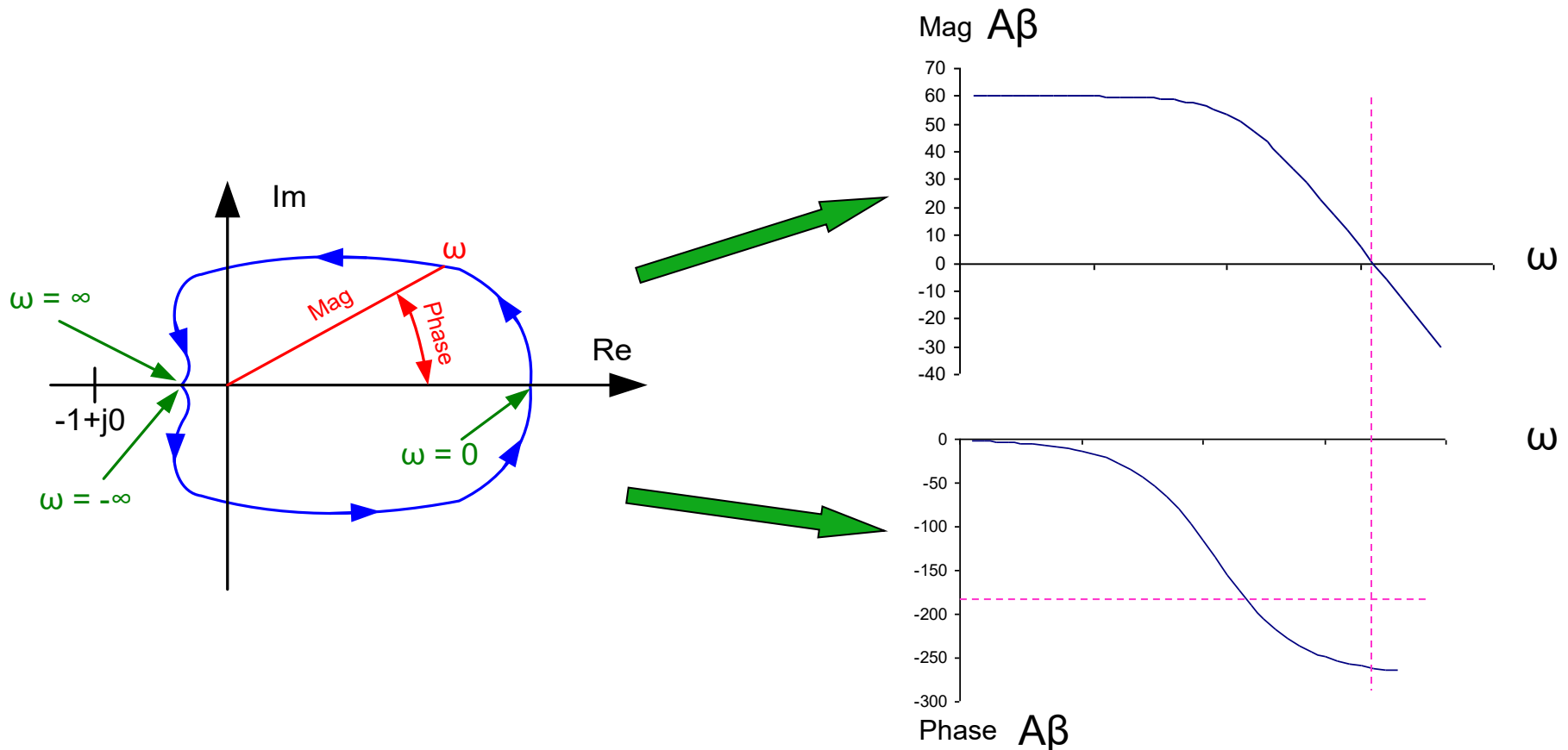

Note: The two plots do not correspond to the same system in this slide

Nyquist and Gain-Phase Plots

Nyquist and Gain-Phase Plots convey **identical** information but gain-phase plots often easier to work with

$$D_{FB}(s) = 1 + A(s)\beta(s)$$

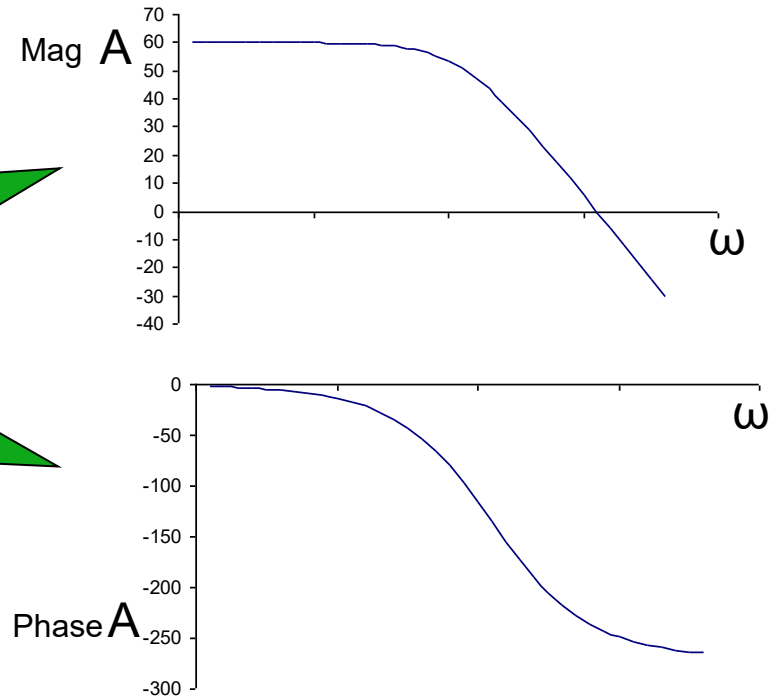
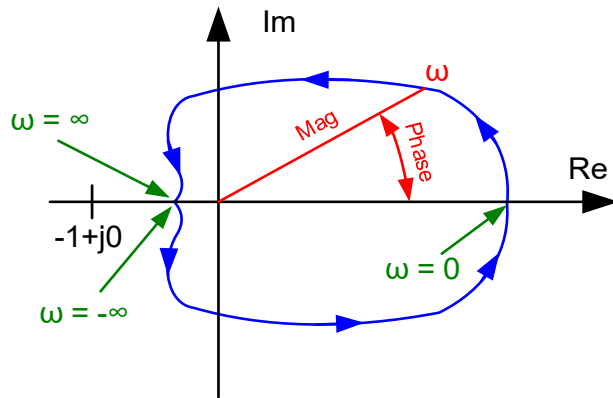

$A\beta$ plots change with different values of β
Often β is independent of frequency

in this case $A\beta$ plot is just a shifted version of A

in this case phase of $A\beta$ is equal to the phase of A

Instead of plotting $A\beta$, often plot $|A|$ and phase of A and superimpose $|\beta^{-1}|$ and phase of β to get gain and phase margins

do not need to replot $|A|$ and phase of A to assess performance with different β

Gain and Phase Margin Examples for $\beta=1$

$$T(s) = \frac{1000}{(s+1)}$$

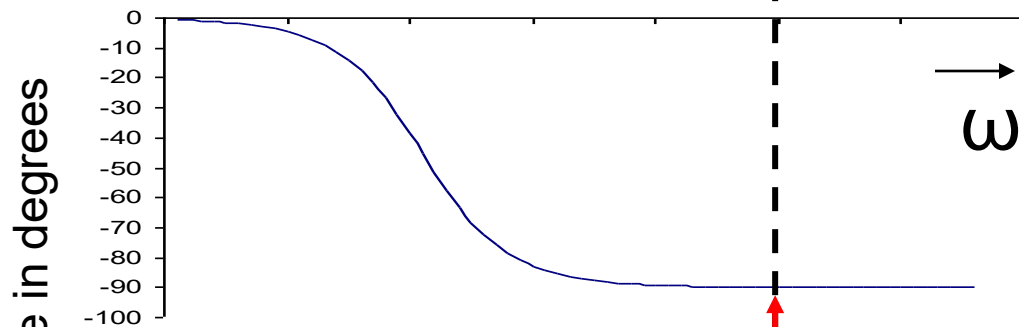
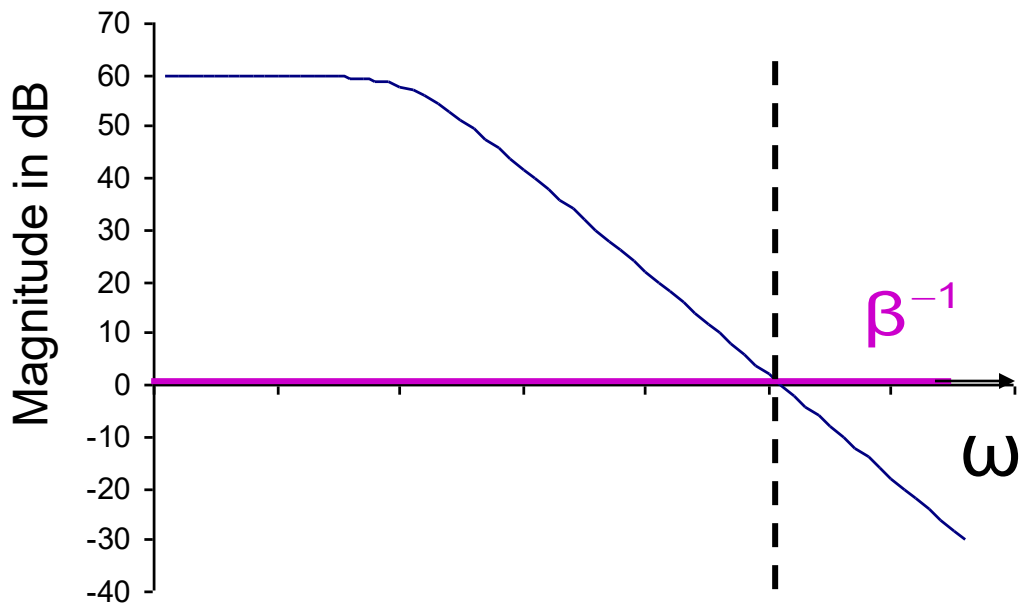

Phase Margin

-180°

Good Phase Margin

Gain and Phase Margin Examples

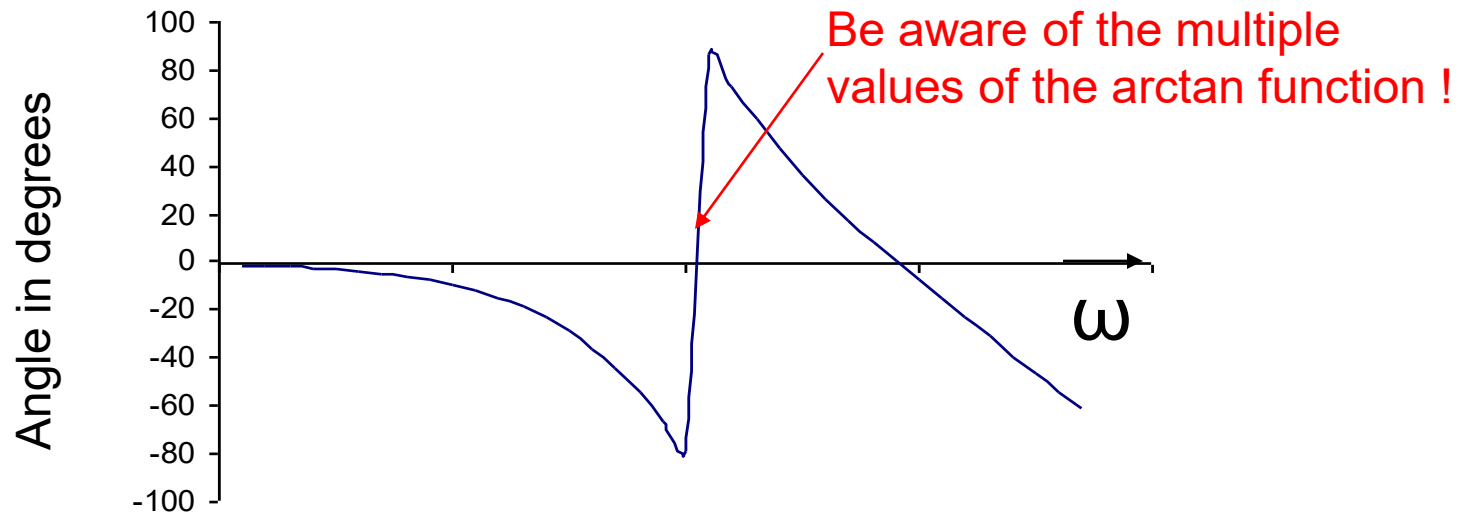
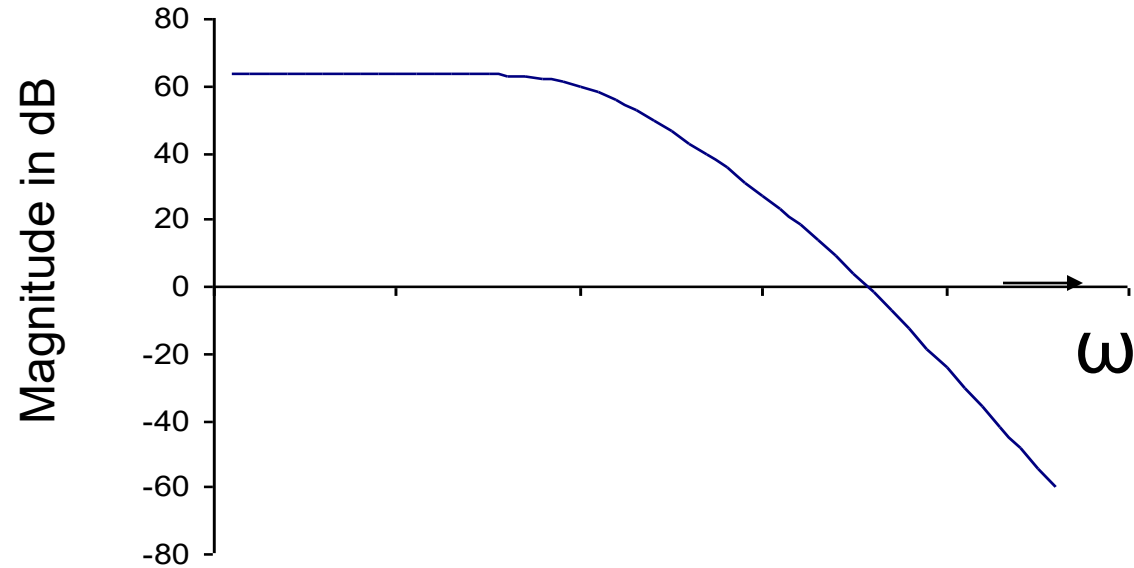

Discontinuities do not exist in magnitude or phase plots

Gain and Phase Margin Examples $\beta=0.1$

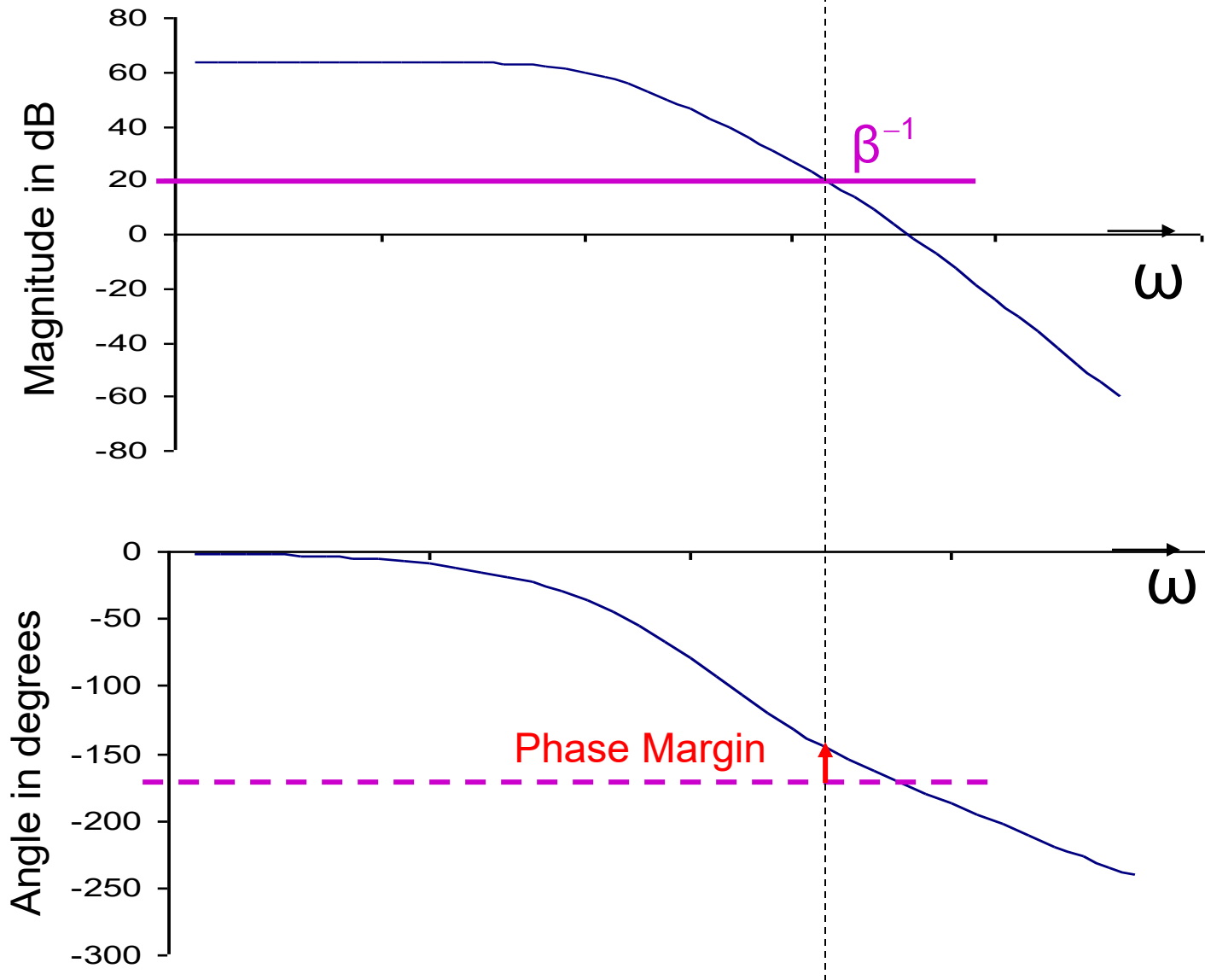

Stable !

But is it a good compensation ?

Gain and Phase Margin Examples $\beta=1$

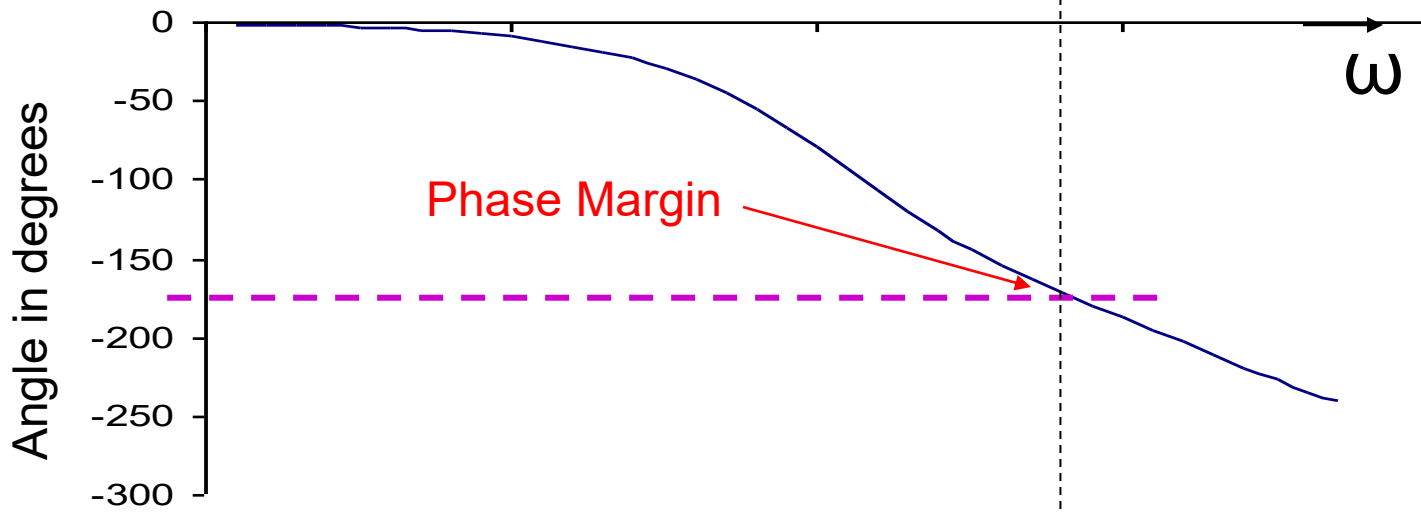
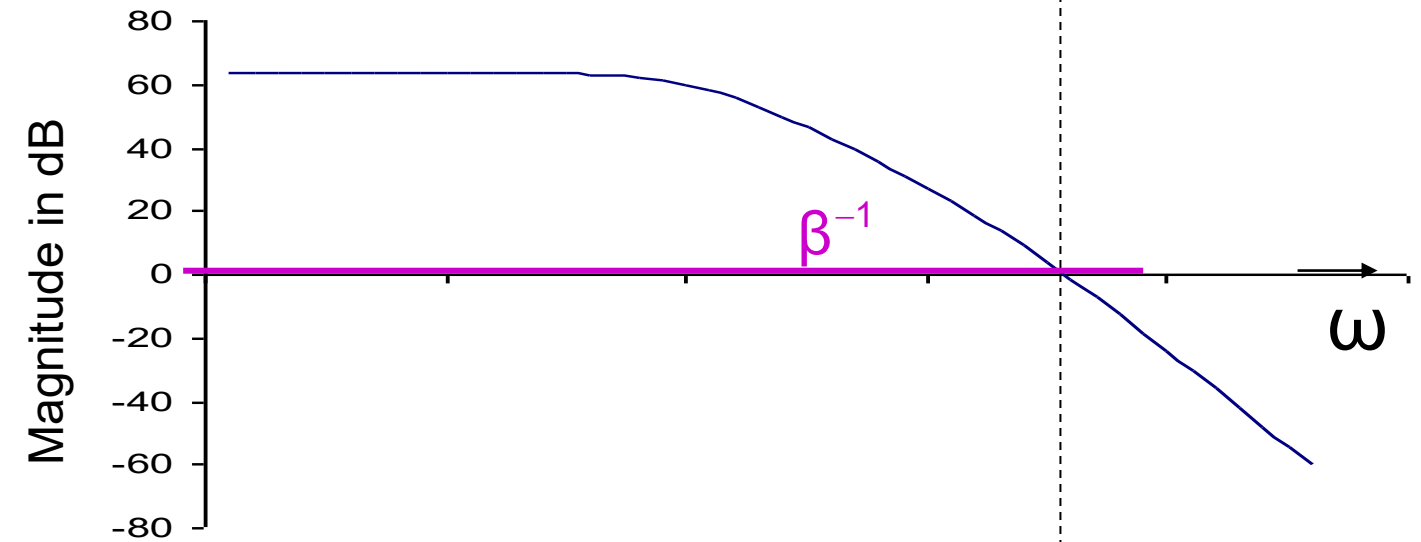

Stable !

But is it a good compensation ?

Gain and Phase Margin Examples

$$A(s) = \frac{1000}{(s+1)\left(\frac{s}{200} + 1\right)}$$

$$\beta = .031$$

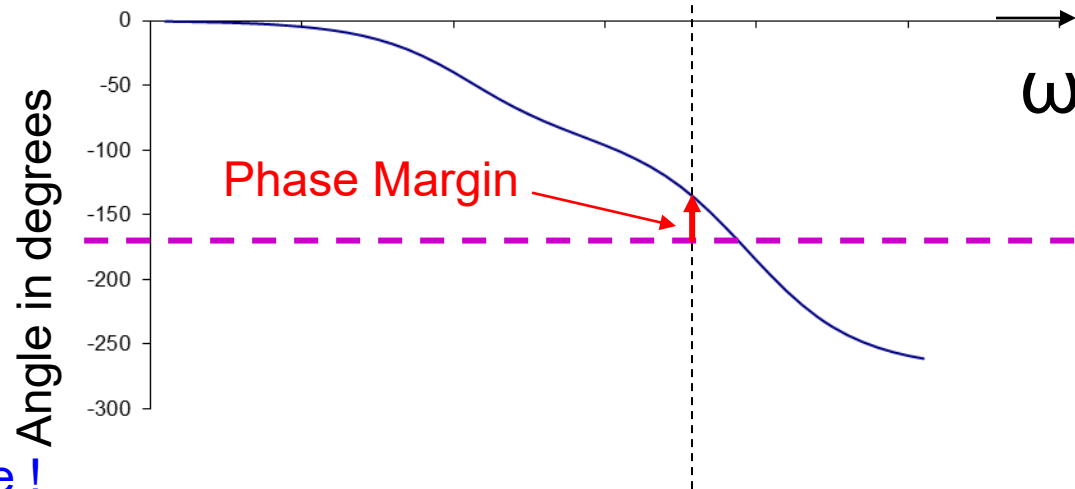
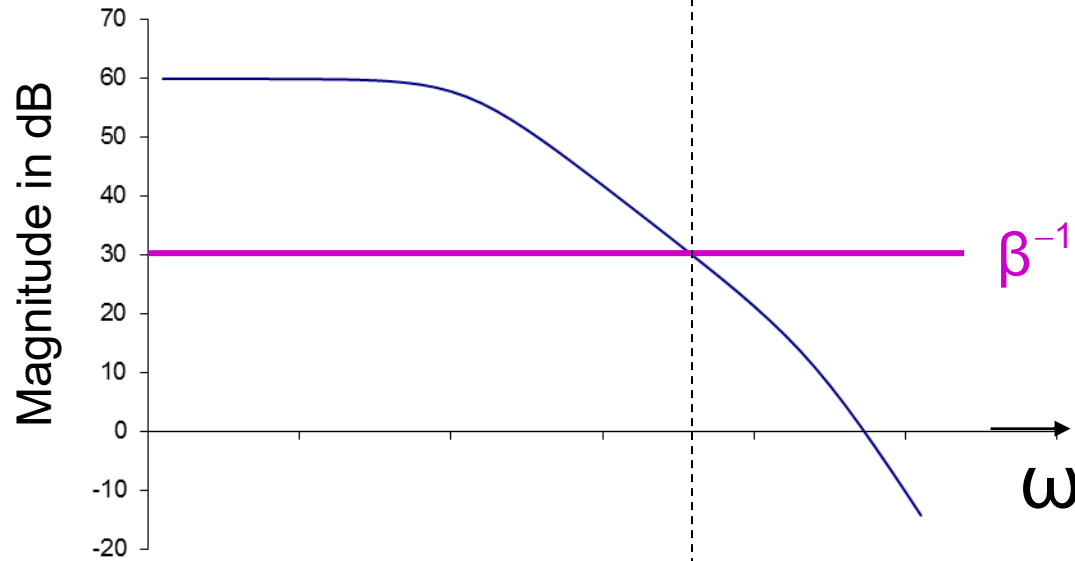

Stable !

But is it a good compensation ?

Gain and Phase Margin Examples

$$A(s) = \frac{1000}{(s+1)\left(\frac{s}{200} + 1\right)}$$

$$\beta = .31$$

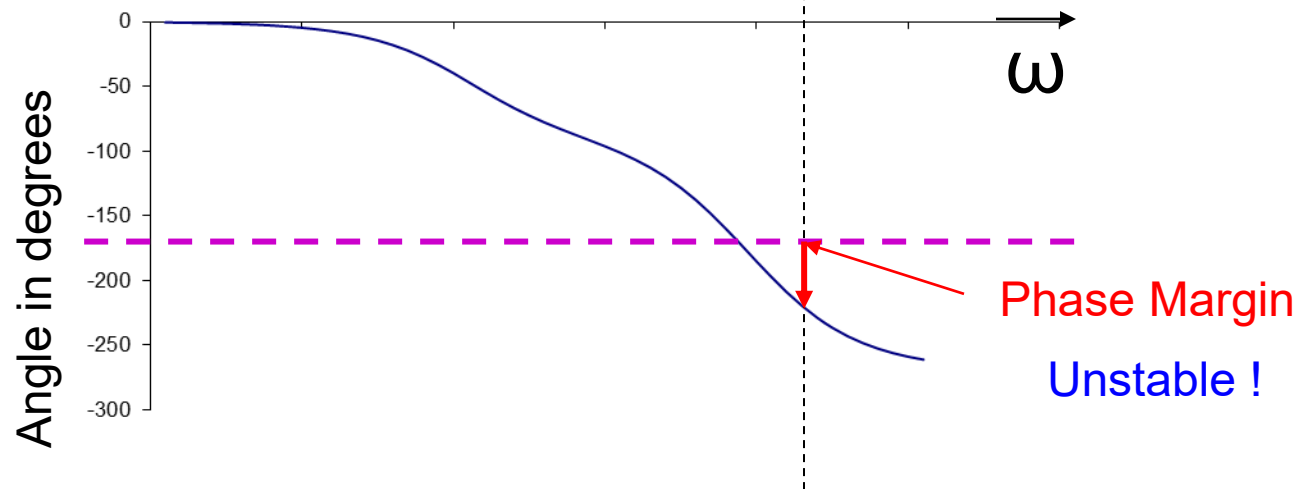

Gain and Phase Margin Examples

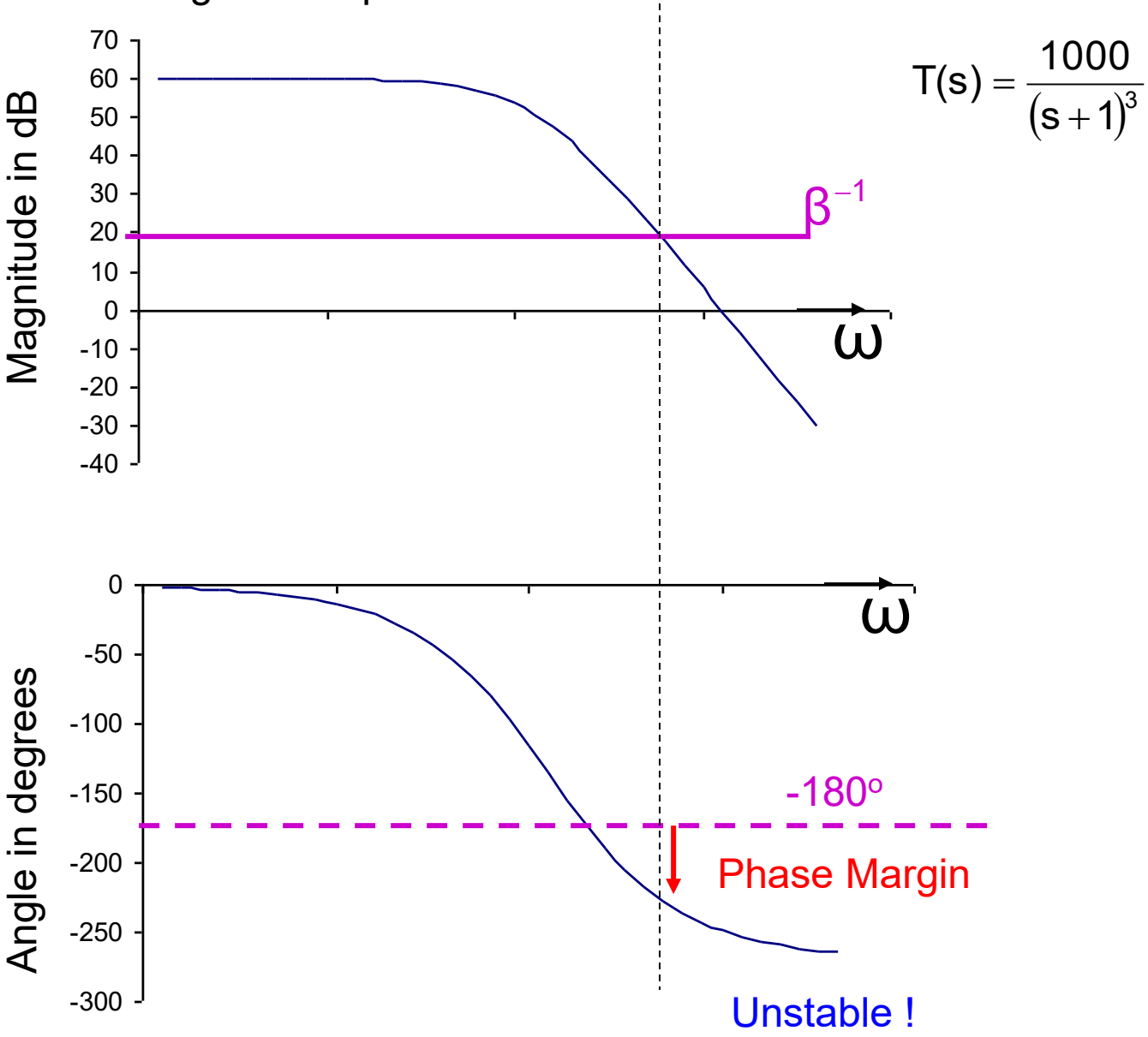

Gain and Phase Margin Examples

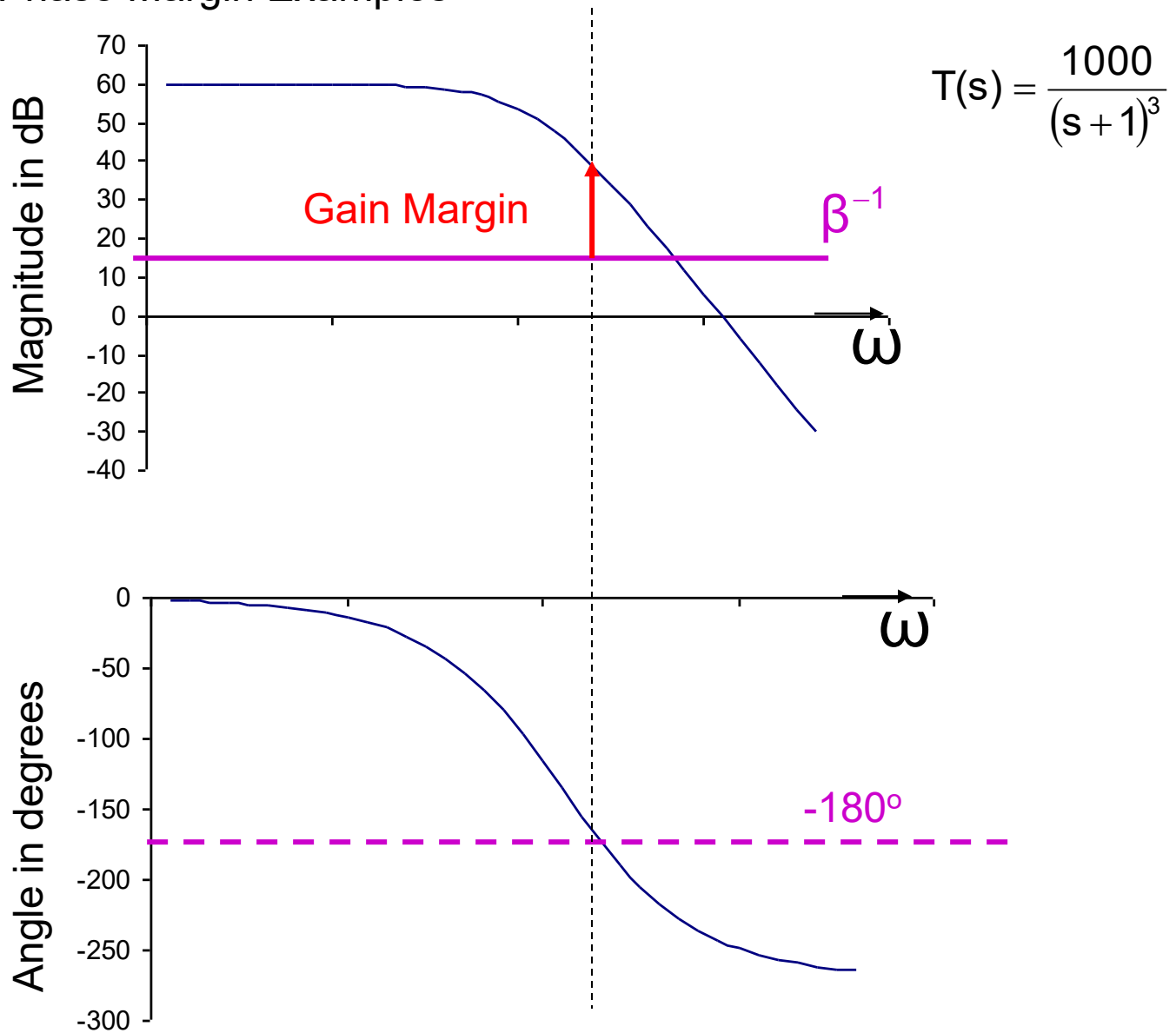

Unstable !

Gain and Phase Margin Examples

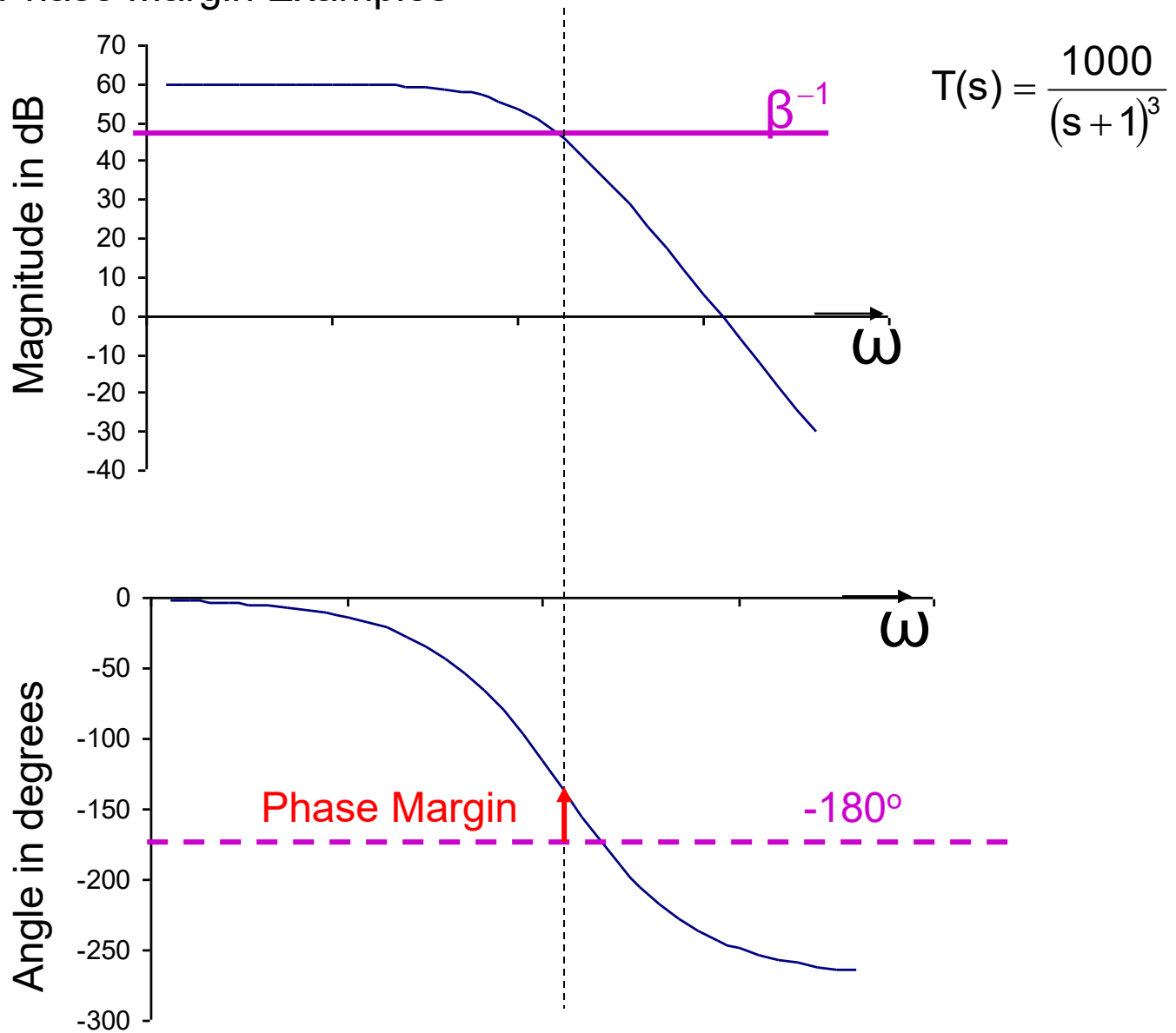

Stable !

But is it a good compensation ?

Gain and Phase Margin Examples

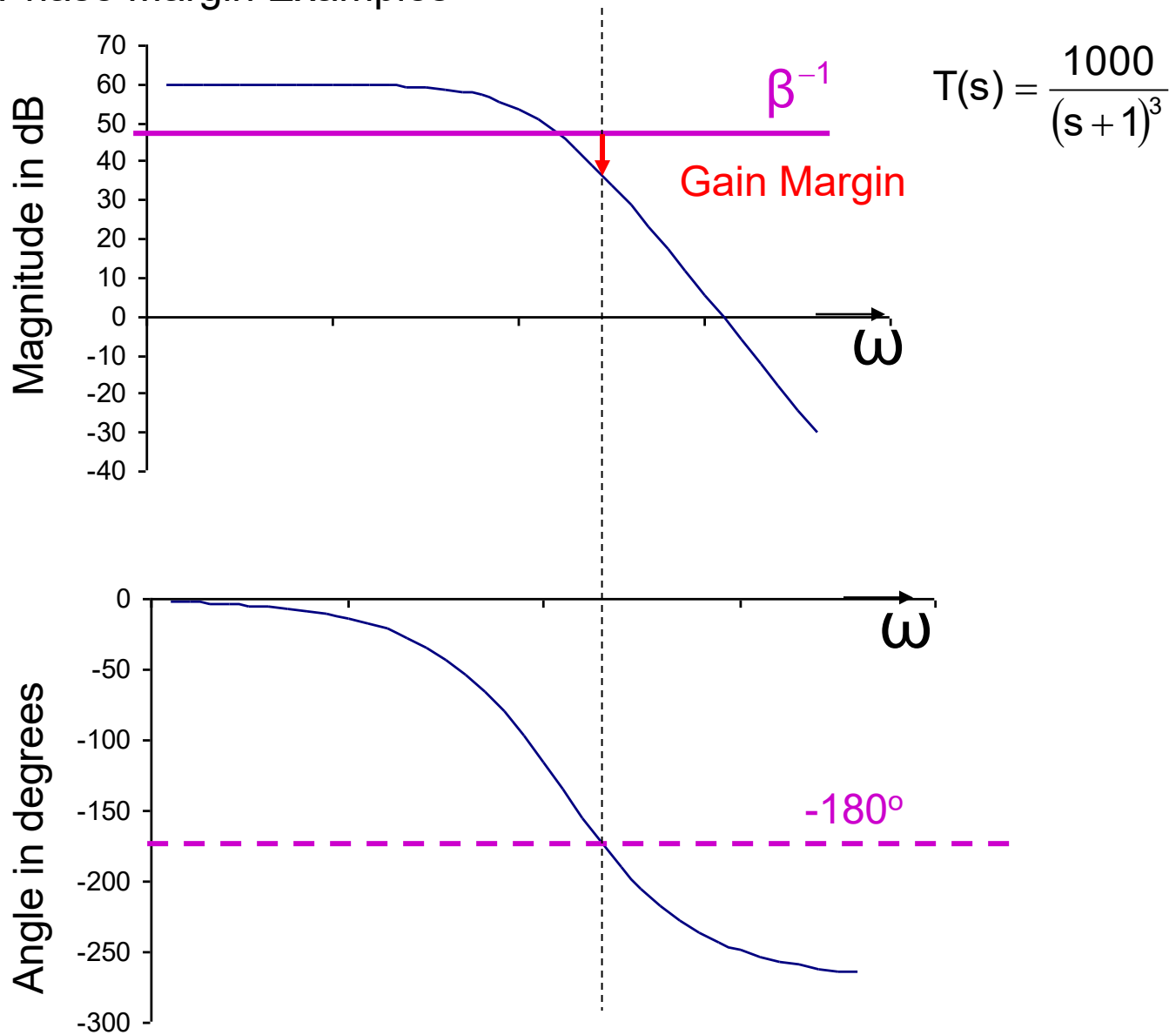

Stable !

But is it a good compensation ?

Gain and Phase Margin Criteria

Now that we know how to get gain-margin and phase-margins, what gain-margin or phase-margin should be targeted?

What considerations should go into making this determination?

Remember gain and phase margin criteria were primarily developed for determining whether a feedback amplifier is stable or unstable

Most authors simply give a number for the desired phase margin or gain margin

There is no natural relationship between gain margin, phase margin and amplifier characteristics such as ringing and overshoot !



Relationship between pole Q and phase margin

In general, the relationship between the phase margin and the pole Q is dependent upon the order of the transfer function and on the location of the zeros

In the special case that the open loop amplifier is second-order low-pass, a closed form analytical relationship between pole Q and phase margin exists and this is independent of A_0 and β .

$$Q = \frac{\sqrt{\cos(\varphi_M)}}{\sin(\varphi_M)} \quad \varphi_M = \cos^{-1} \left(\sqrt{1 + \frac{1}{4Q^4}} - \frac{1}{2Q^2} \right)$$

The region of interest is invariable only for $0.5 < Q < 0.7$
larger Q introduces unacceptable ringing and settling
smaller Q slows the amplifier down too much

Phase Margin vs Q

Second-order low-pass Amplifier

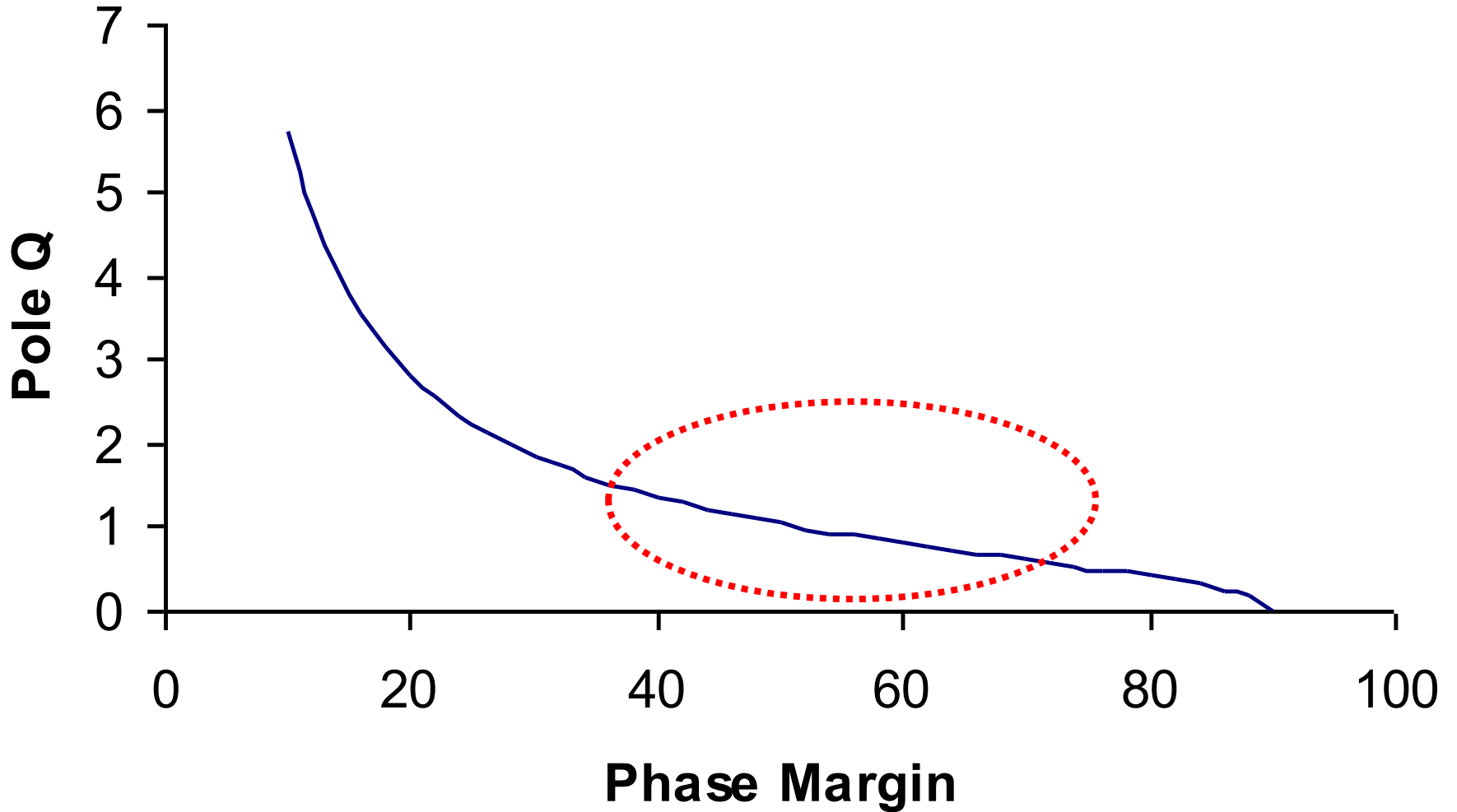

Phase Margin vs Q

Second-order low-pass Amplifier

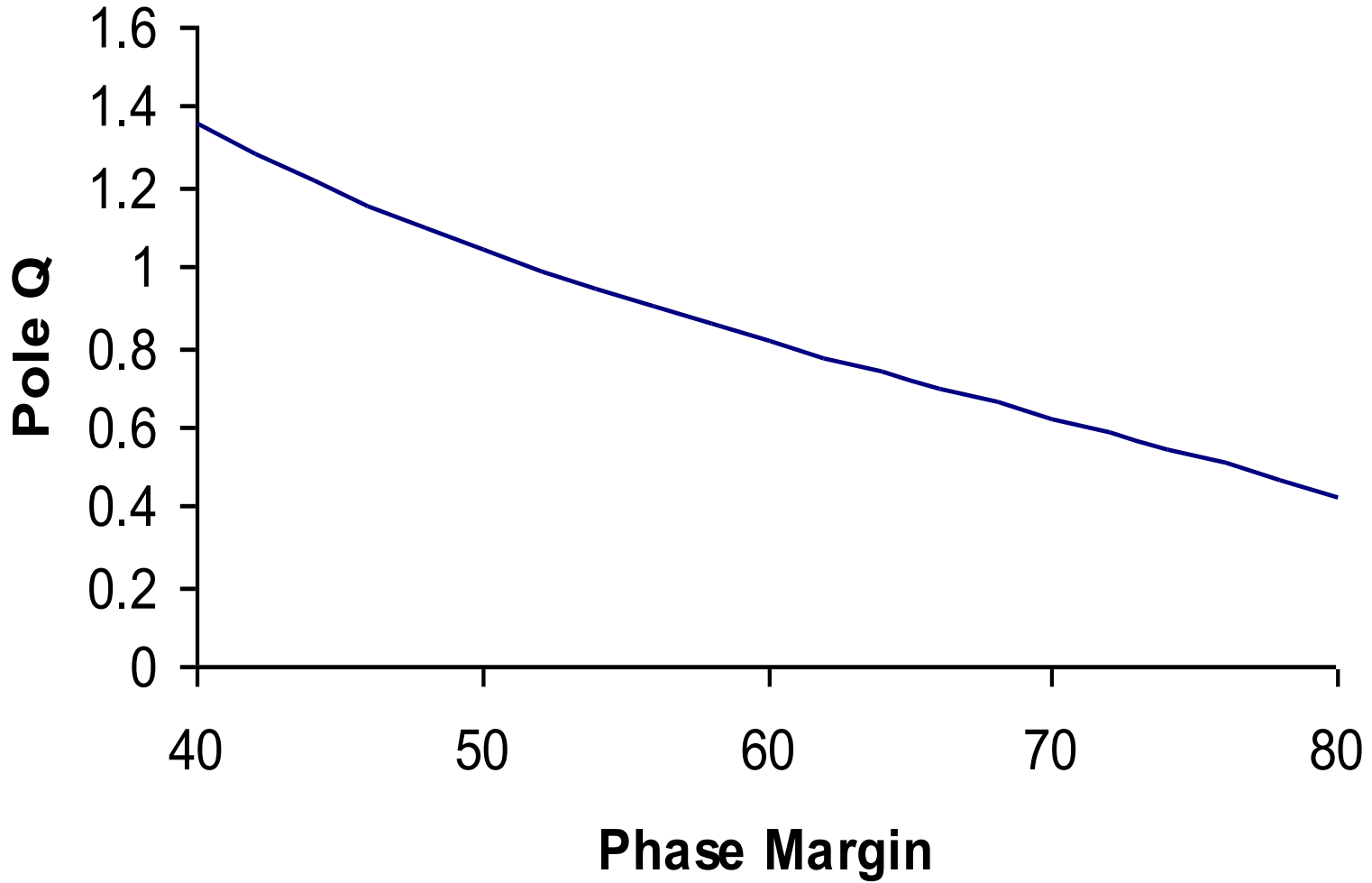

Phase Margin vs Q

Second-order low-pass Amplifier

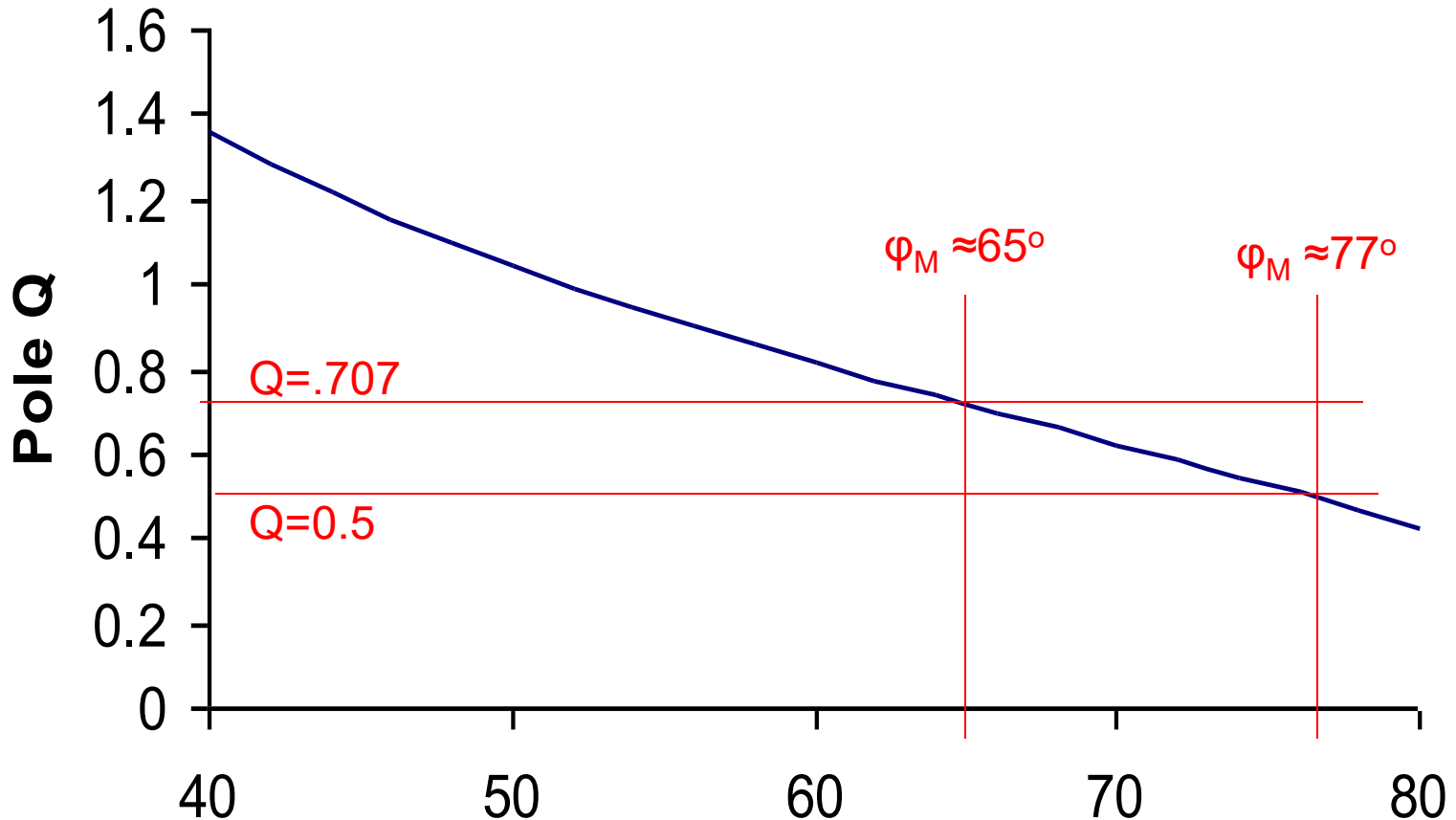

$.707 < Q < 0.5$



$65^\circ < \phi_M < 75^\circ$

Phase-Margin Compensation Criteria

Phase Margin vs Q

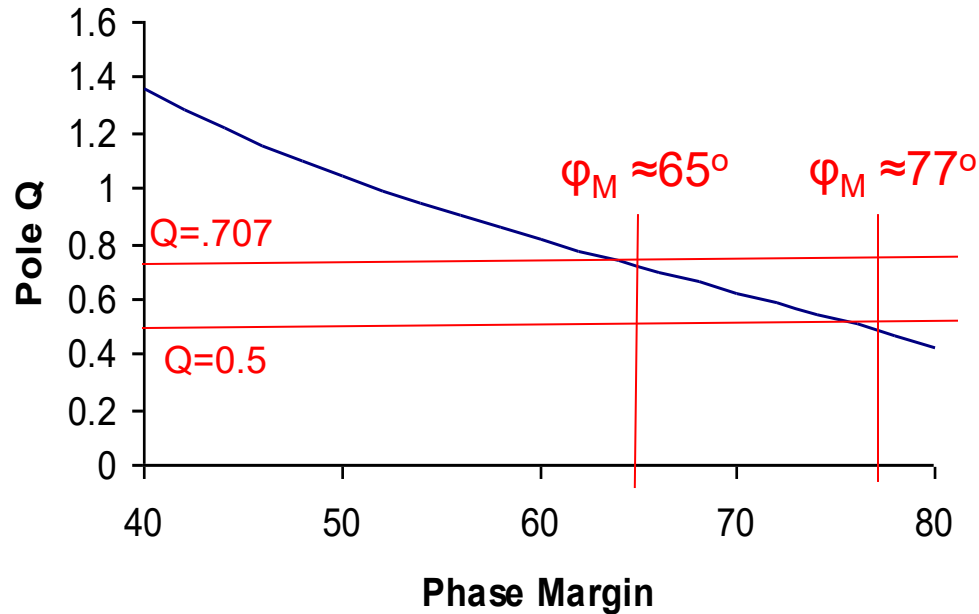

$$.707 < Q < 0.5$$



$$65^\circ < \varphi_M < 75^\circ$$

- This relationship holds only for 2nd-order low-pass open loop amplifiers
- Considerable evidence of use of these phase margin criteria when not 2nd-order low-pass but not clear what relevance this may have for FB performance



Stay Safe and Stay Healthy !

End of Lecture 16